

MATERIAL LIST

MAIN COMPONENTS	MATERIAL
PIPES	316SS
GAUGE	300 SERIES STAINLESS STEEL
GAS TUBING	PTFE
SOLENOID VALVE	316SS

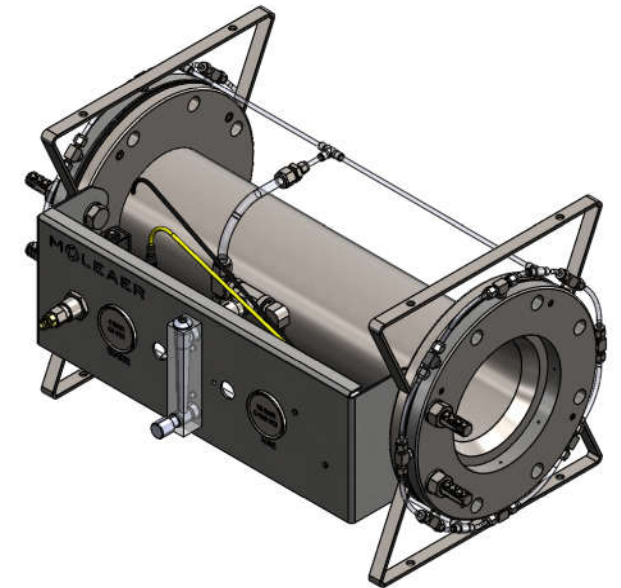
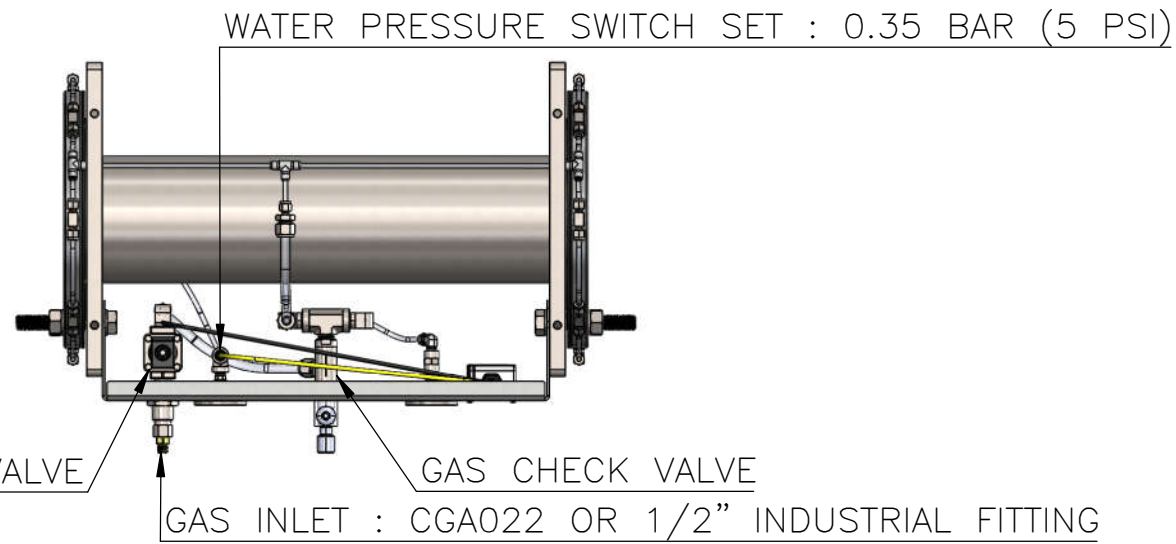

WATER PRESSURE GAUGE
0-4 BAR (0-60 PSI)

GAS PRESSURE GAUGE
0-12 BAR (0-160 PSI)

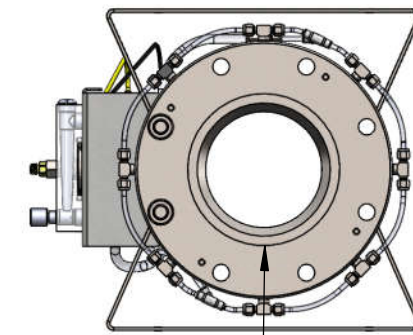
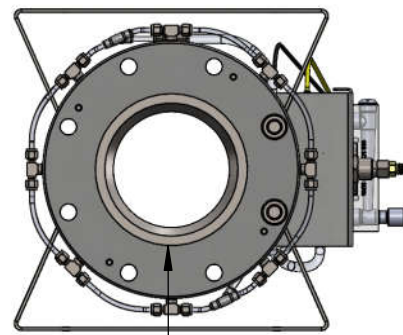
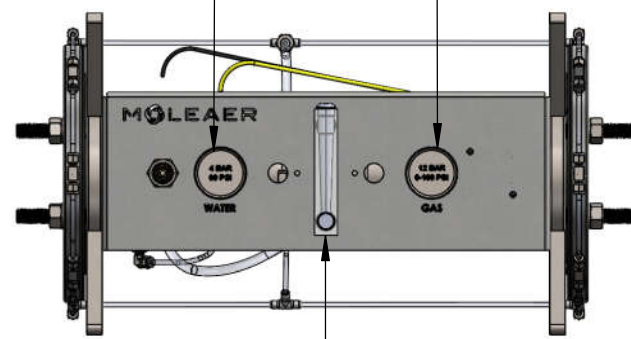

JUNCTION BOX
BLK : +
WHT : -

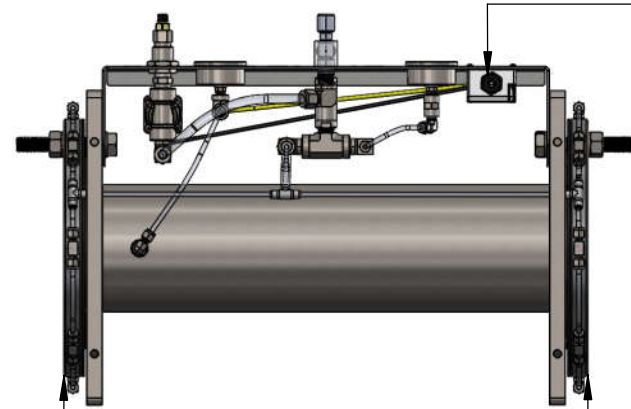

UNLESS OTHERWISE SPECIFIED: DIMENSIONS IN mm TOLERANCES ARE ±6.35	DRAWN BY M.CHA	DATE 09/08/23
	CHECKED BY P.MAHMOUDIAN	DATE 09/15/23
	APPROVED BY P.MAHMOUDIAN	DATE 09/15/23
PROPRIETARY AND CONFIDENTIAL INFORMATION CONTAINED IN THIS DRAWING IS THE SOLE PROPERTY OF "MOLEAER INC". ANY REPRODUCTION IN PART OR WHOLE WITHOUT THE WRITTEN PERMISSION OF "MOLEAER INC" IS PROHIBITED.		

		3232 W. EL SEGUNDO BLVD HAWTHORNE CA, 90250	
DRAWING TITLE: NBG 6, 316SS, METRIC, GAD			
DRAWING NO: 50F1-801			
		SIZE: B	SCALE: 1:10
		SHEET: 1/2	REV: A

REV.	BY	DESCRIPTION	ECO	DATE	CHECKED	APPROVED
A	MC	INITIAL RELEASE	2025	09/08/23	PM	PM
REVISIONS						

NOTE :
ALL DIMENSIONS ARE IN mm[INCHES]

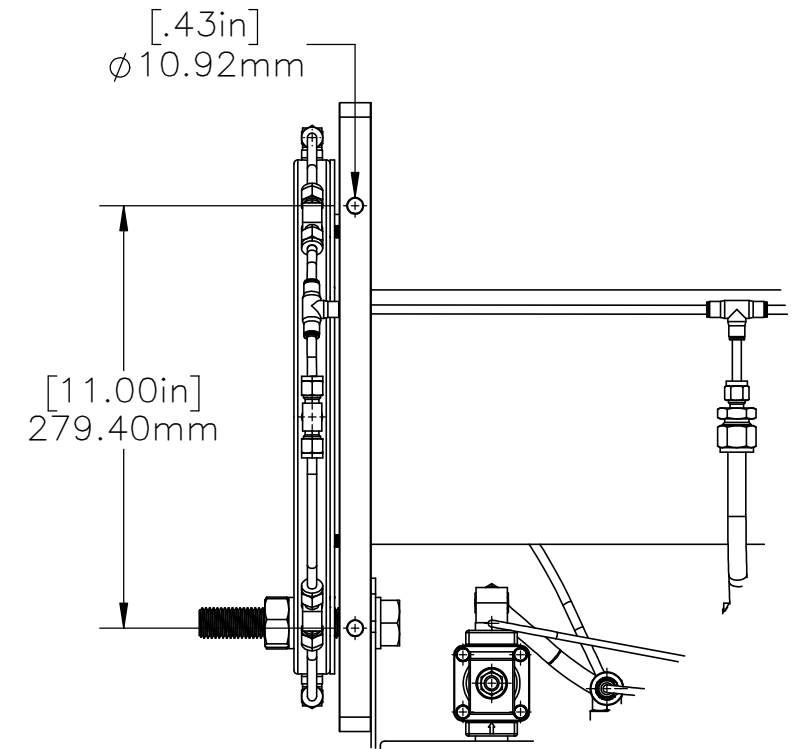
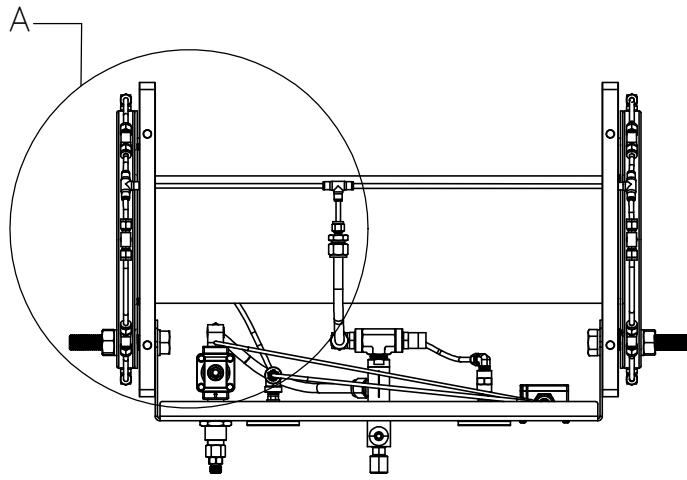

DETAIL A
SCALE 1 : 5

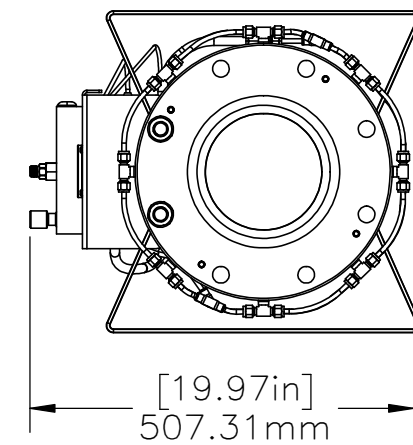
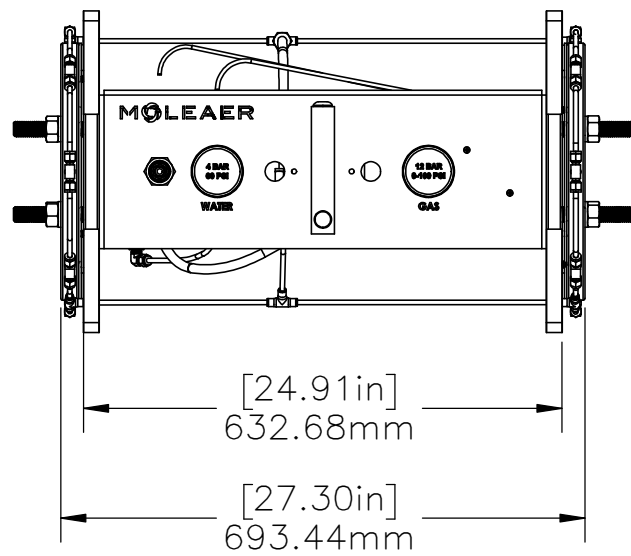
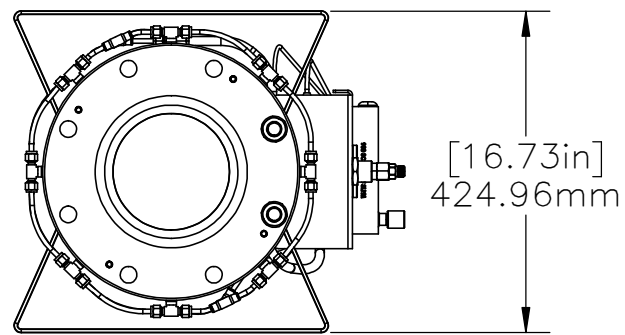

UNLESS OTHERWISE SPECIFIED: DIMENSIONS IN mm TOLERANCES ARE ±6.35	DRAWN BY M.CHA	DATE 09/08/23	3232 W. EL SEGUNDO BLVD HAWTHORNE CA, 90250 DRAWING TITLE: NBG 6, 316SS, METRIC, GAD DRAWING NO: 50F1-801
	CHECKED BY P.MAHMOUDIAN	DATE 09/15/23	
	APPROVED BY P.MAHMOUDIAN	DATE 09/15/23	
PROPRIETARY AND CONFIDENTIAL INFORMATION CONTAINED IN THIS DRAWING IS THE SOLE PROPERTY OF "MOLEAER INC". ANY REPRODUCTION IN PART OR WHOLE WITHOUT THE WRITTEN PERMISSION OF "MOLEAER INC" IS PROHIBITED.			SIZE: B SCALE: 1:10 SHEET: 2/2 REV: A

REV.	BY	DESCRIPTION	ECO	DATE	CHECKED	APPROVED
A	MC	INITIAL RELEASE	2025	09/08/23	PM	PM
REVISIONS						