

MATERIAL LIST	
MAIN COMPONENT	MATERIAL
PIPES	316SS
GAUGES	300 SERIES STAINLESS STEEL
GAS TUBING	PTFE
SOLENOID VALVE	316SS
BUTTERFLY VALVE	316SS, FKM
CIP VALVE	316SS, PTFE

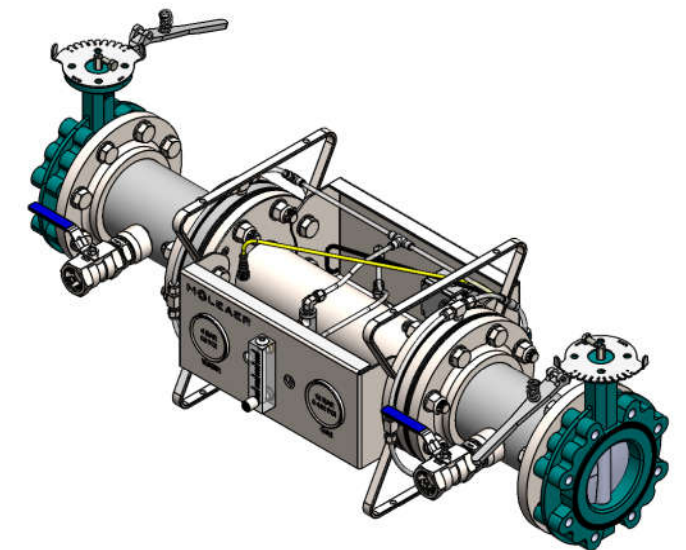

WATER PRESSURE GAUGE 0-4 BAR (0-60 PSI) GAS PRESSURE GAUGE 0-12 BAR (0-160 PSI)

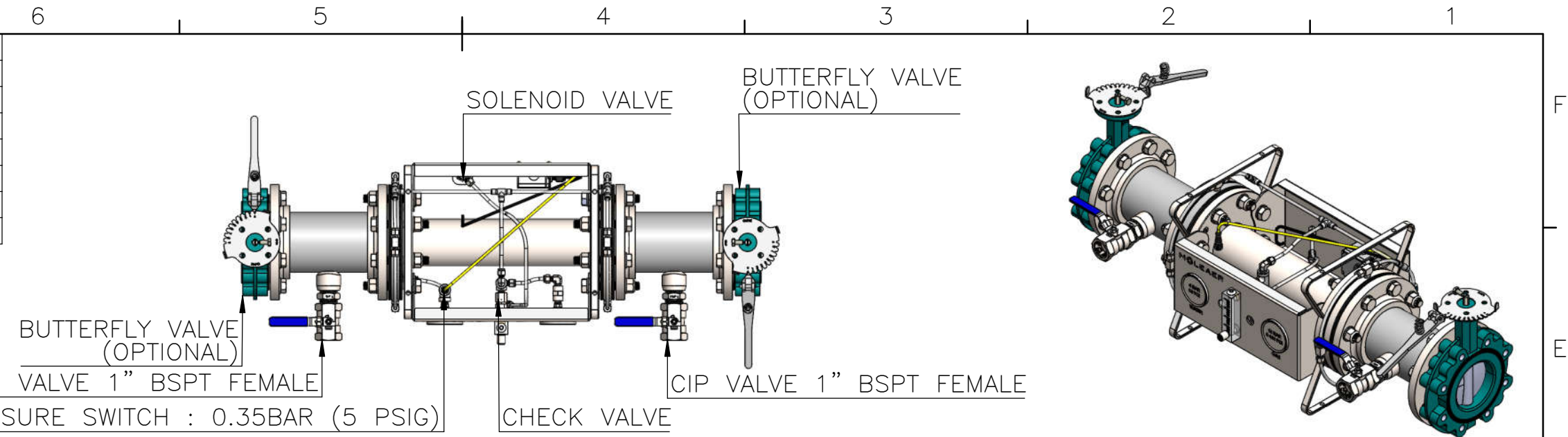
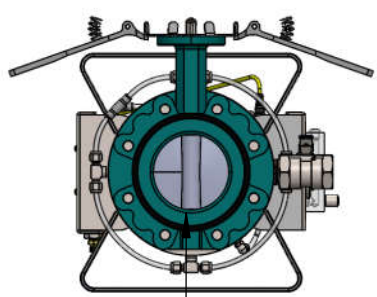

WATER INLET : D100mm

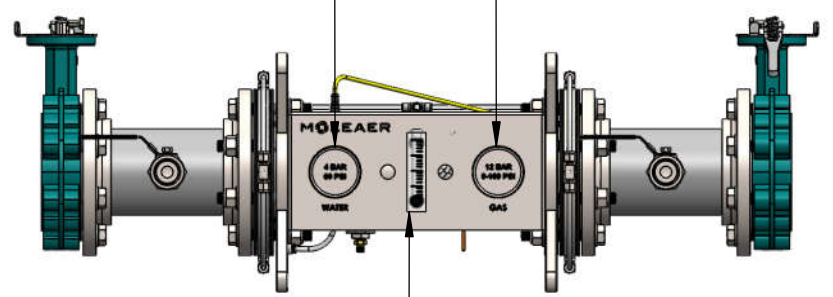

ROTAMETER RANGE : 240SCFH & 115SLPM

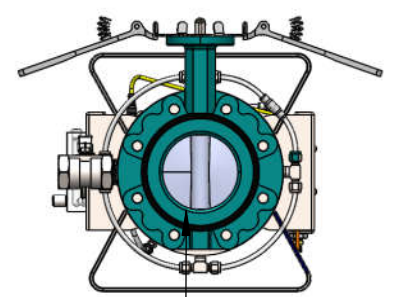

WATER OUTLET : D100mm

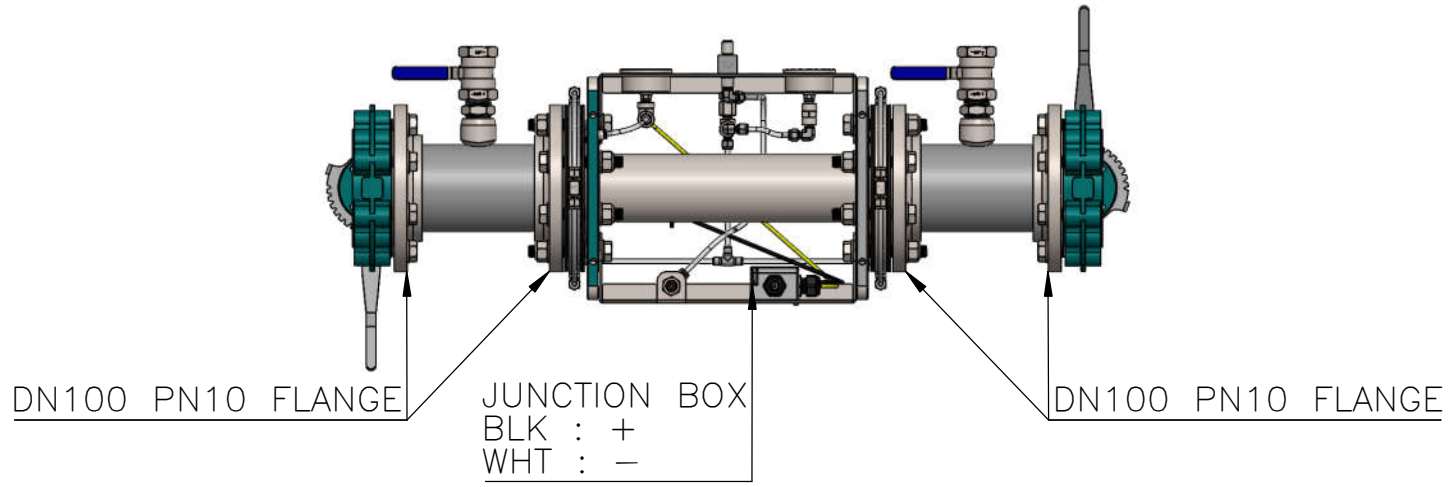

UNLESS OTHERWISE SPECIFIED: DIMENSIONS IN INCHES[mm] TOLERANCES ARE ±0.250[±6.35]	DRAWN BY M.CHA	DATE 11/13/23
	CHECKED BY P.MAHMOUDIAN	DATE 11/16/23
	APPROVED BY P.MAHMOUDIAN	DATE 11/16/23
PROPRIETARY AND CONFIDENTIAL INFORMATION CONTAINED IN THIS DRAWING IS THE SOLE PROPERTY OF "MOLEAER INC". ANY REPRODUCTION IN PART OR WHOLE WITHOUT THE WRITTEN PERMISSION OF "MOLEAER INC" IS PROHIBITED.		

 3232 W. EL SEGUNDO BLVD
 HAWTHORNE CA, 90250
 DRAWING TITLE: TRINITY L1, 316SS, METRIC, GAD
 DRAWING NO:
 50F1-300(WITH BUTTERFLY VALVE)
 50F2-300(WITHOUT BUTTERFLY VALVE)

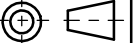
 SIZE: B SCALE: 1:10 SHEET: 1/2 REV: A

REV.	BY	DESCRIPTION	ECO	DATE	CHECKED	APPROVED
A	MC	INITIAL RELEASE	2047	11/13/23	PM	PM
REVISIONS						

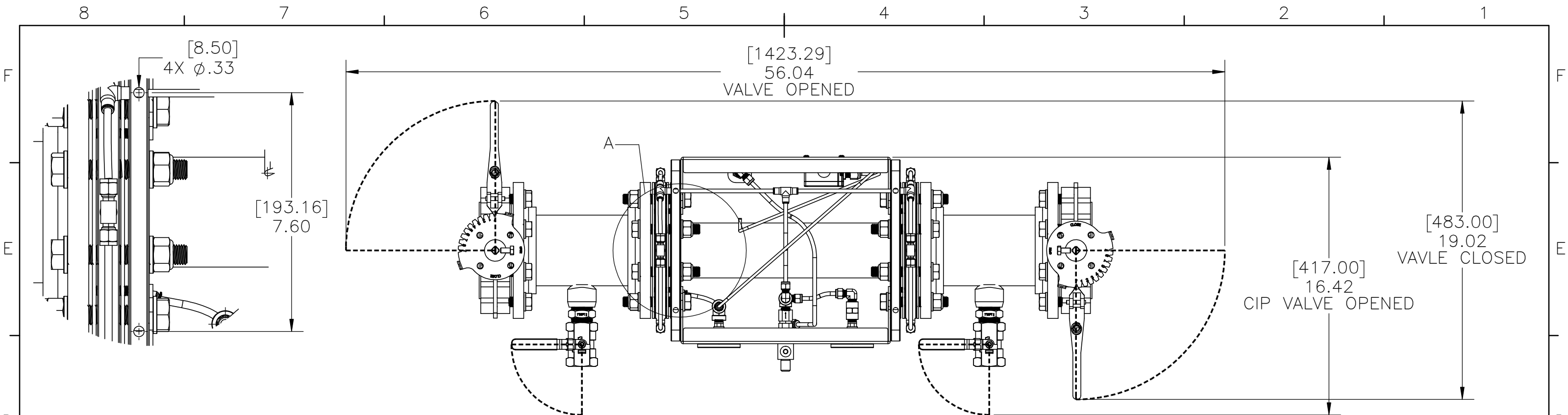

DETAIL A
SCALE 1 : 3

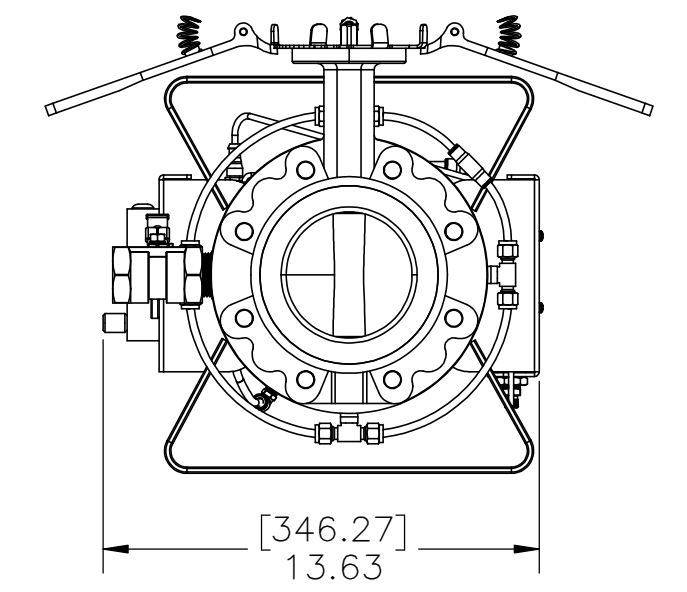
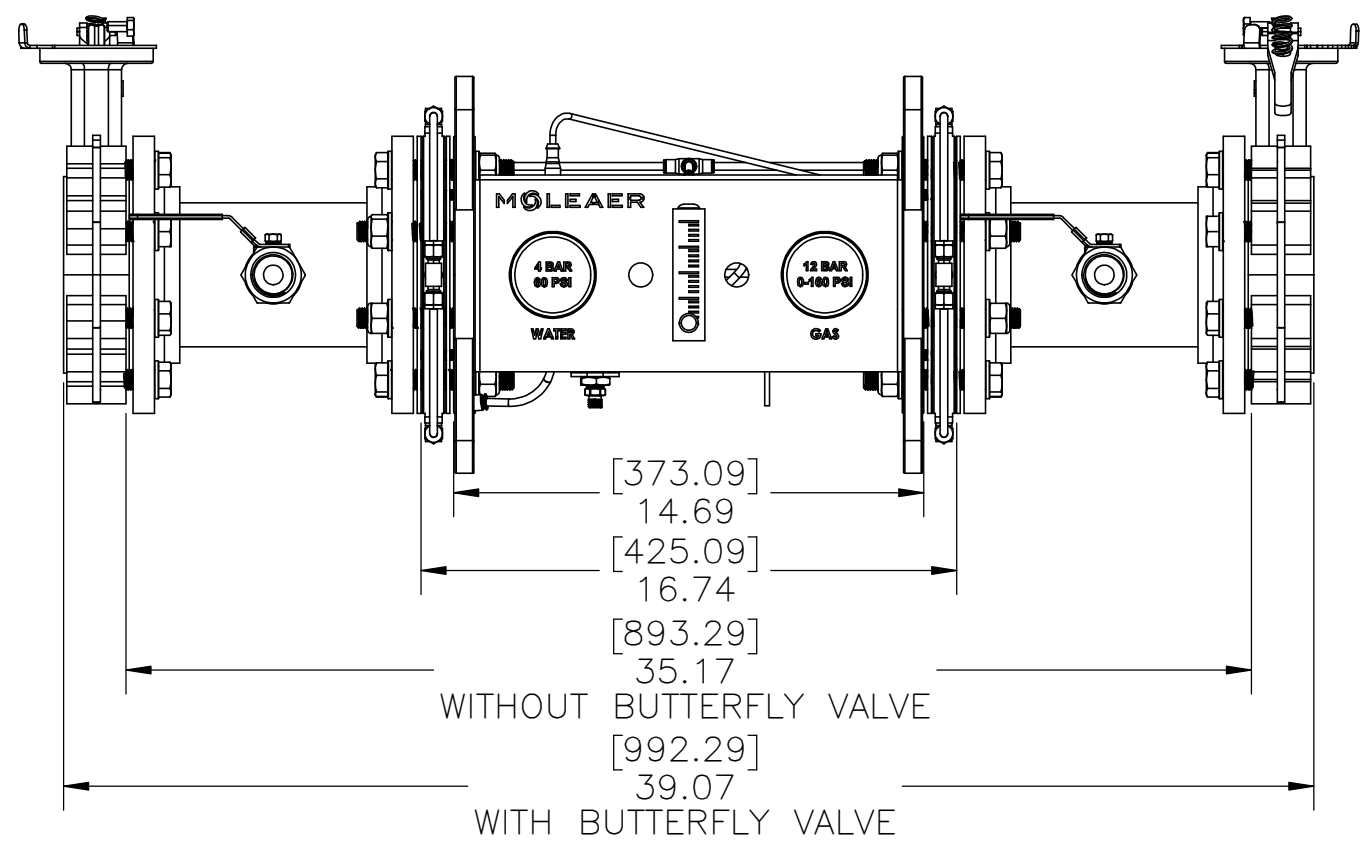
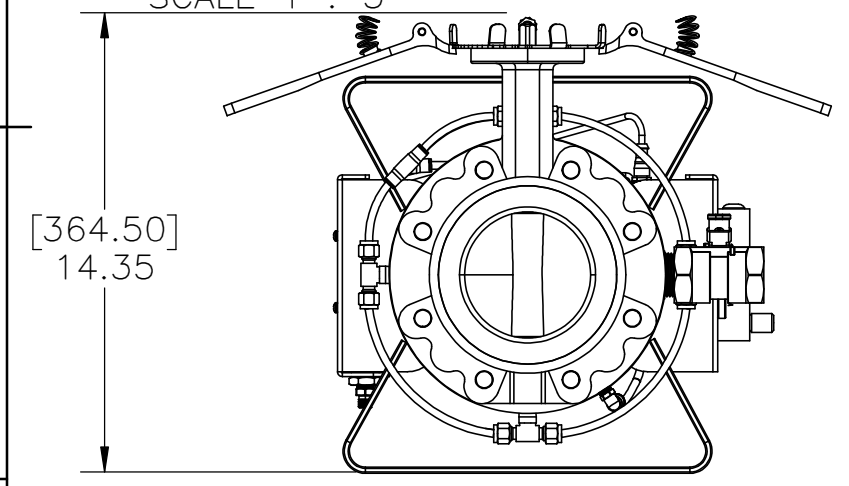

REV.	BY	DESCRIPTION	ECO	DATE	CHECKED	APPROVED
A	MC	INITIAL RELEASE	2047	11/13/23	PM	PM
REVISIONS						

UNLESS OTHERWISE SPECIFIED:
 DIMENSIONS IN INCHES[mm]
 TOLERANCES ARE ±0.250[±6.35]

DRAWN BY M.CHA	DATE 11/13/23
CHECKED BY P.MAHMOUDIAN	DATE 11/16/23
APPROVED BY P.MAHMOUDIAN	DATE 11/16/23

PROPRIETARY AND CONFIDENTIAL
 INFORMATION CONTAINED IN THIS DRAWING IS THE SOLE PROPERTY OF "MOLEAER INC". ANY REPRODUCTION IN PART OR WHOLE WITHOUT THE WRITTEN PERMISSION OF "MOLEAER INC" IS PROHIBITED.

MOLEAER 3232 W. EL SEGUNDO BLVD
HAWTHORNE CA, 90250

DRAWING TITLE: TRINITY L1, 316SS, METRIC, GAD

DRAWING NO:
50F1-300(WITH BUTTERFLY VALVE)
50F2-300(WITHOUT BUTTERFLY VALVE)

SIZE: B SCALE: 1:10 SHEET: 2/2 REV: A