

MATERIAL LIST

MAIN COMPONENTS	MATERIAL
PIPES	316SS
GAUGE	300 SERIES STAINLESS STEEL
GAS TUBING	PTFE
SOLENOID VALVE	316SS

JUNCTION BOX  
BLK : +  
WHT : -

SOLENOID VALVE

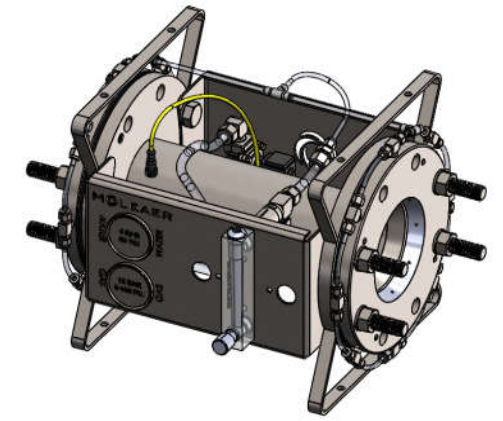
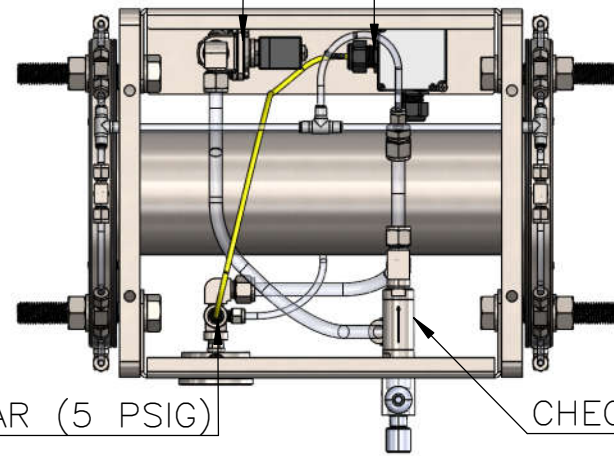

WATER PRESSURE SWITCH : 0.35 BAR (5 PSIG)

CHECK VALVE

WATER PRESSURE GAUGE 0-4 BAR (0-60 PSI)

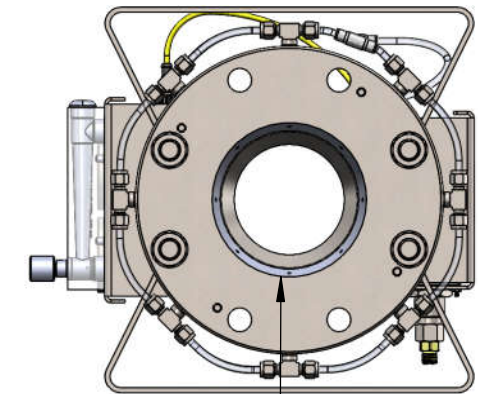
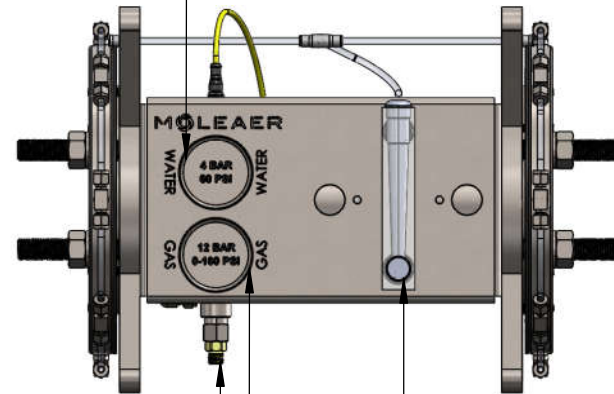
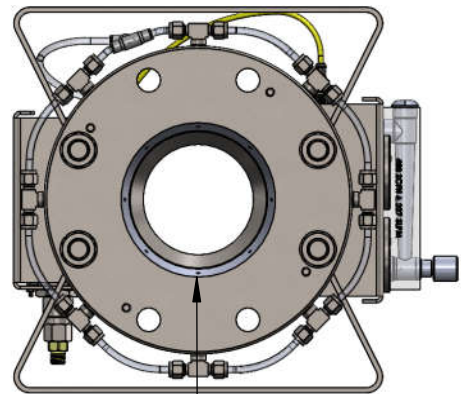

GAS INLET : CGA022 OR 1/2" NPT INDUSTRIAL FITTING

ROTAMETER RANGE : 480SCFH & 227SLPM

GAS PRESSURE GAUGE 0-12 BAR (0-160 PSI)

WATER OUTLET : 150mm

WATER INLET : D150mm

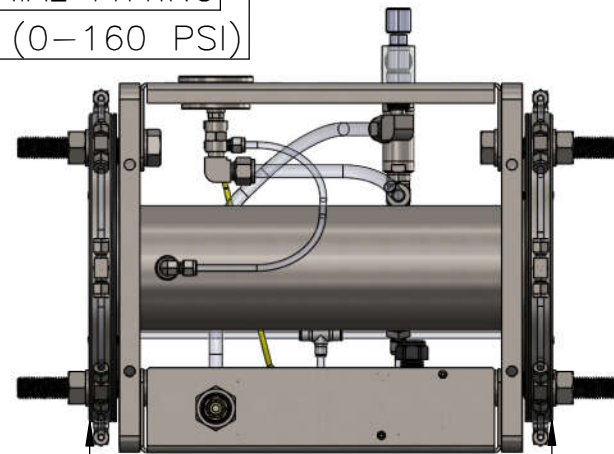

DN150 PN10 FLANGE

DN150 PN10 FLANGE

UNLESS OTHERWISE SPECIFIED:  DIMENSIONS IN mm[INCHES] TOLERANCES ARE ±6.35[±0.250]	DRAWN BY M.CHA	DATE 09/27/23
	CHECKED BY P.MAHMOUDIAN	DATE 10/02/23
	APPROVED BY P.MAHMOUDIAN	DATE 10/02/23

**MOLEAER** 3232 W. EL SEGUNDO BLVD  
HAWTHORNE CA, 90250

DRAWING TITLE: NBG 4, 316SS, METRIC, GAD

DRAWING NO: 50F1-100

PROPRIETARY AND CONFIDENTIAL  
INFORMATION CONTAINED IN THIS DRAWING IS THE SOLE PROPERTY OF "MOLEAER INC". ANY REPRODUCTION IN PART OR WHOLE WITHOUT THE WRITTEN PERMISSION OF "MOLEAER INC" IS PROHIBITED.

SIZE: B SCALE: 1:10 SHEET: 1/2 REV: A

REV.	BY	DESCRIPTION	ECO	DATE	CHECKED	APPROVED
A	MC	INITIAL RELEASE	2033	09/27/23	PM	PM

REVISIONS

NOTE :  
ALL DIMENSIONS ARE IN mm[INCHES]

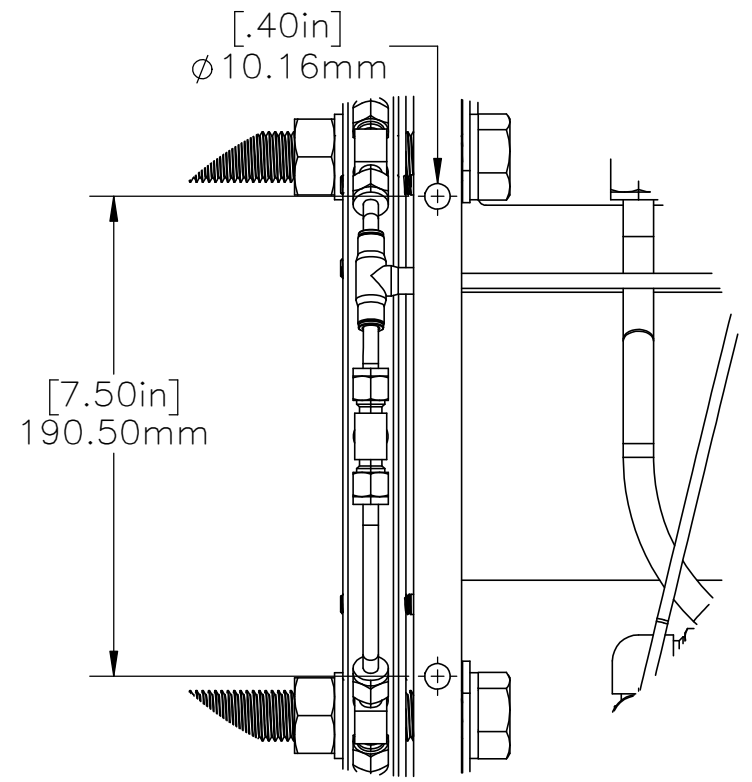
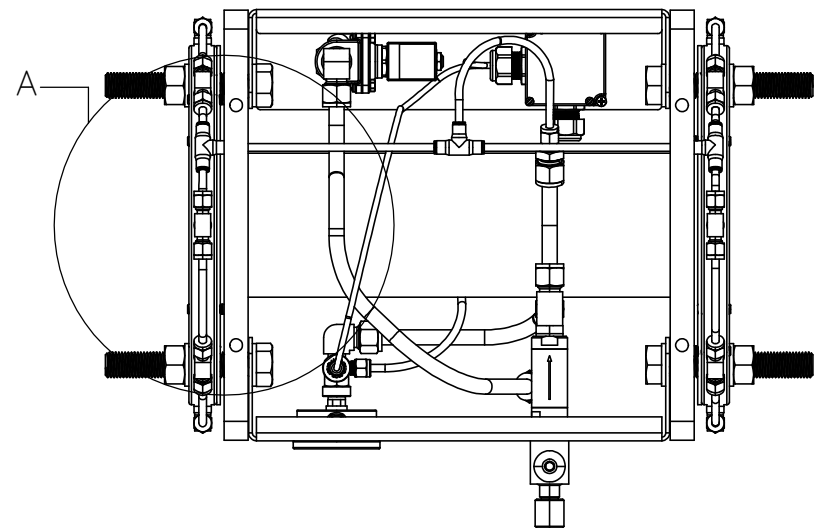

DETAIL A  
SCALE 1 : 3

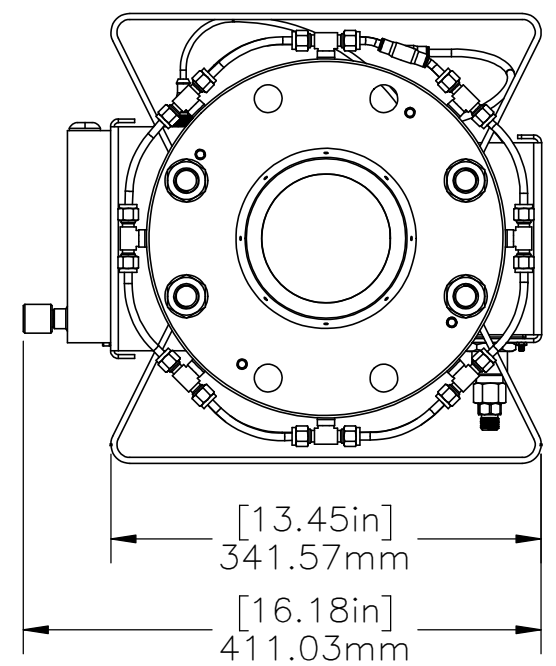
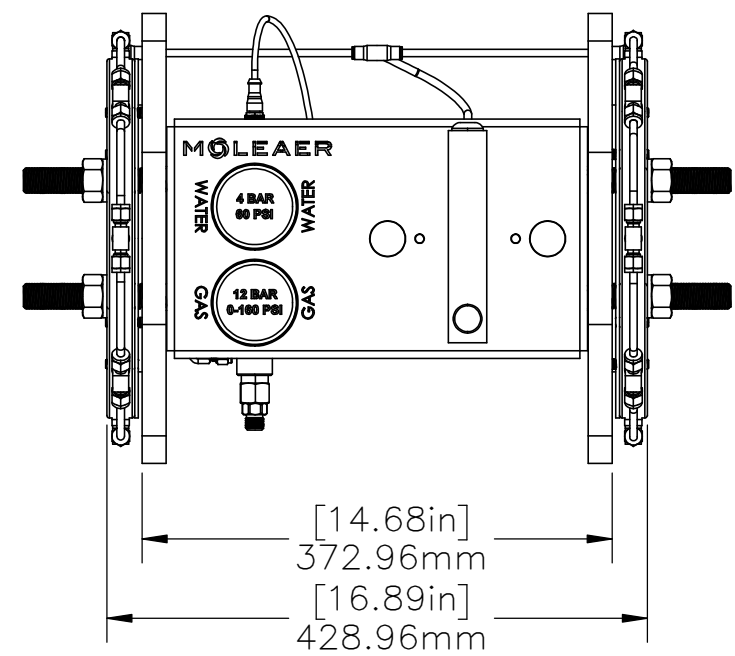
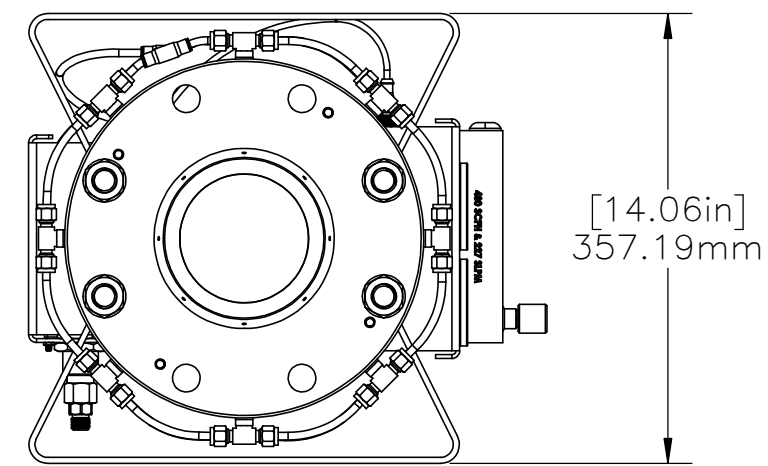

UNLESS OTHERWISE SPECIFIED: DIMENSIONS IN mm[INCHES] TOLERANCES ARE $\pm 6.35[\pm 0.250]$		DRAWN BY M.CHA	DATE 09/27/23	3232 W. EL SEGUNDO BLVD HAWTHORNE CA, 90250 DRAWING TITLE: NBG 4, 316SS, METRIC, GAD DRAWING NO: 50F1-100
		CHECKED BY P.MAHMOUDIAN	DATE 10/02/23	
		APPROVED BY P.MAHMOUDIAN	DATE 10/02/23	
<b>PROPRIETARY AND CONFIDENTIAL</b> INFORMATION CONTAINED IN THIS DRAWING IS THE SOLE PROPERTY OF "MOLEAER INC". ANY REPRODUCTION IN PART OR WHOLE WITHOUT THE WRITTEN PERMISSION OF "MOLEAER INC" IS PROHIBITED.				SIZE: B SCALE: 1:10 SHEET: 2/2 REV: A

REV.	BY	DESCRIPTION	ECO	DATE	CHECKED	APPROVED
A	MC	INITIAL RELEASE	2033	09/27/23	PM	PM
REVISIONS						