

MATERIAL LIST

MAIN COMPONENTS	MATERIAL
PIPES	HDPE
GAUGES	300 SERIES STAINLESS STEEL
GAS TUBING	PTFE
SOLENOID VALVE	316SS

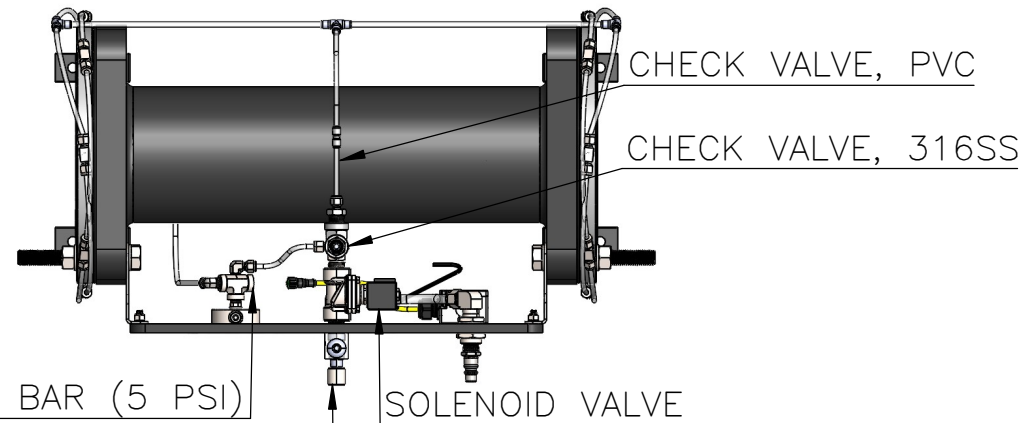

WATER PRESSURE SWITCH SET : 0.35 BAR (5 PSI)  
ROTAMETER : 900SCFH & 425SLPM

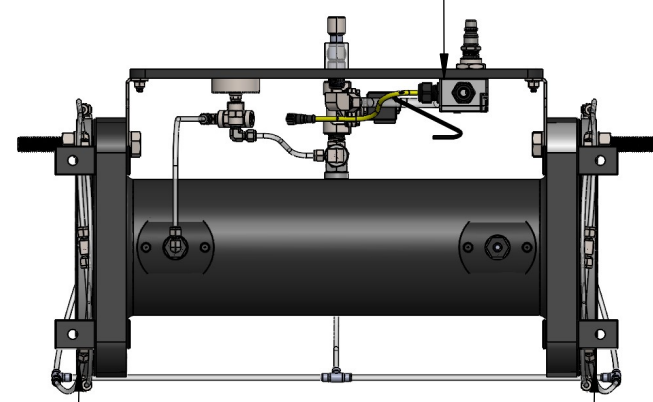
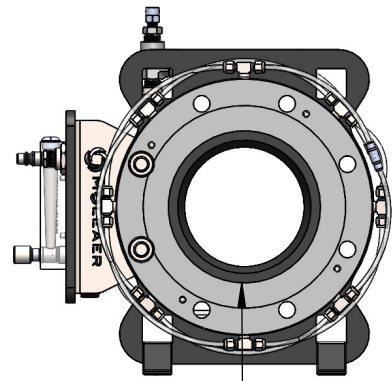
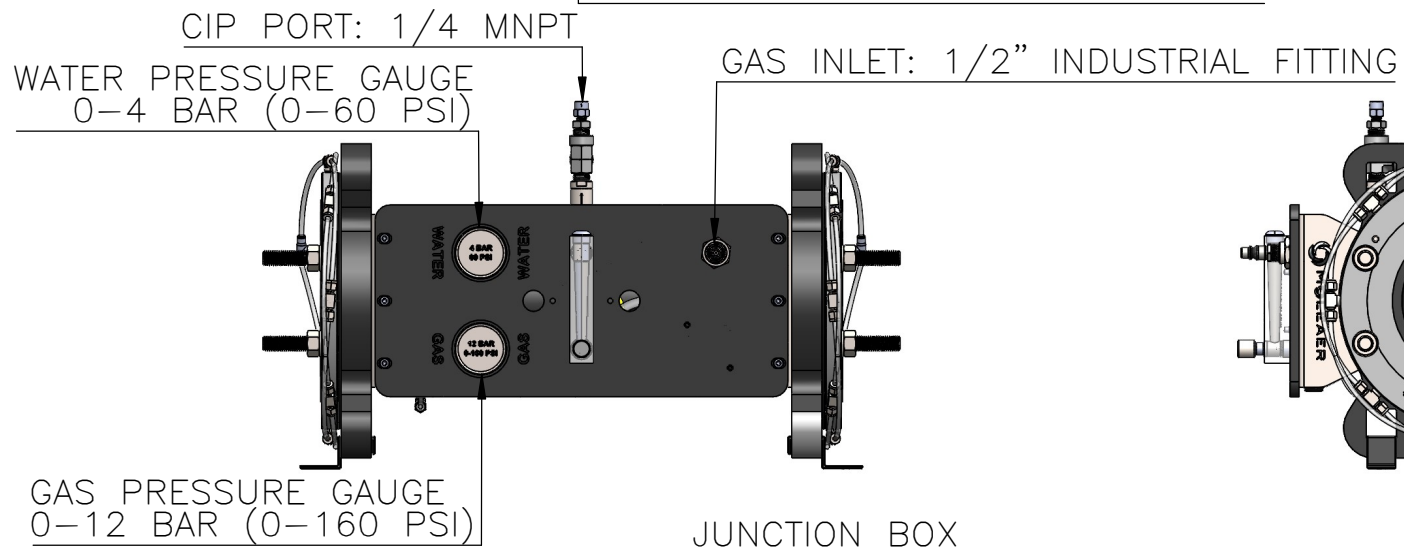
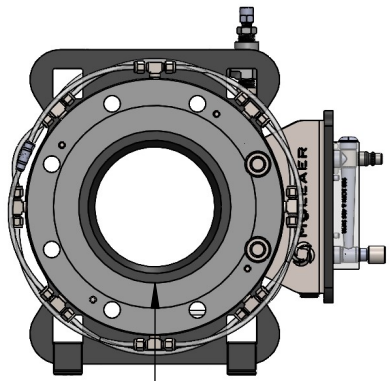

REV.	BY	DESCRIPTION	ECO	DATE	CHECKED	APPROVED
B	EC	ADDED CHECK VALVES & CIP PORT	2069	02/28/24	MC	PM
A	MC	INITIAL RELEASE	2040	10/26/23	PM	PM



UNLESS OTHERWISE SPECIFIED: DIMENSIONS IN INCHES[mm] TOLERANCES ARE ±0.250[±6.35]	DRAWN BY M.CHA CHECKED BY P.MAHMOUDIAN APPROVED BY P.MAHMOUDIAN	DATE 10/26/23 DATE 11/27/23 DATE 11/27/23
PROPRIETARY AND CONFIDENTIAL INFORMATION CONTAINED IN THIS DRAWING IS THE SOLE PROPERTY OF "MOLEAER INC". ANY REPRODUCTION IN PART OR WHOLE WITHOUT THE WRITTEN PERMISSION OF "MOLEAER INC" IS PROHIBITED.		

3232 W. EL SEGUNDO BLVD  
HAWTHORNE CA, 90250  
 DRAWING TITLE:  
**NBG 6, HDPE, METRIC, GAD**  
 DRAWING NO:  
**50F2-800**

SIZE: B SCALE: 1:10 SHEET: 1/2 REV: B

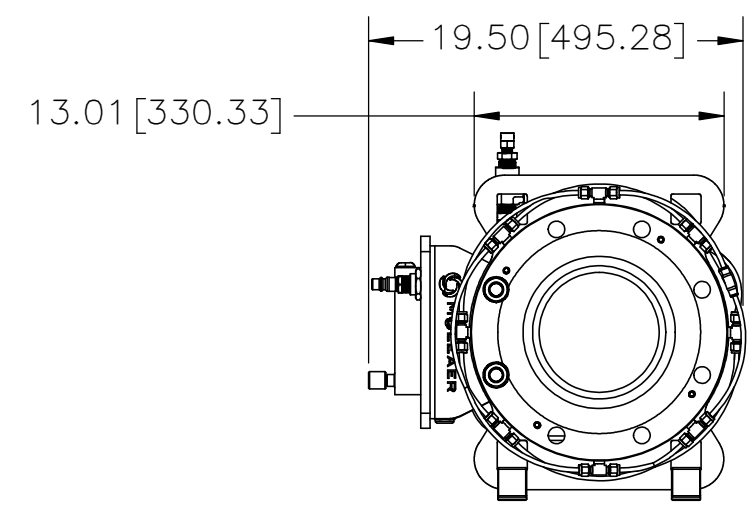
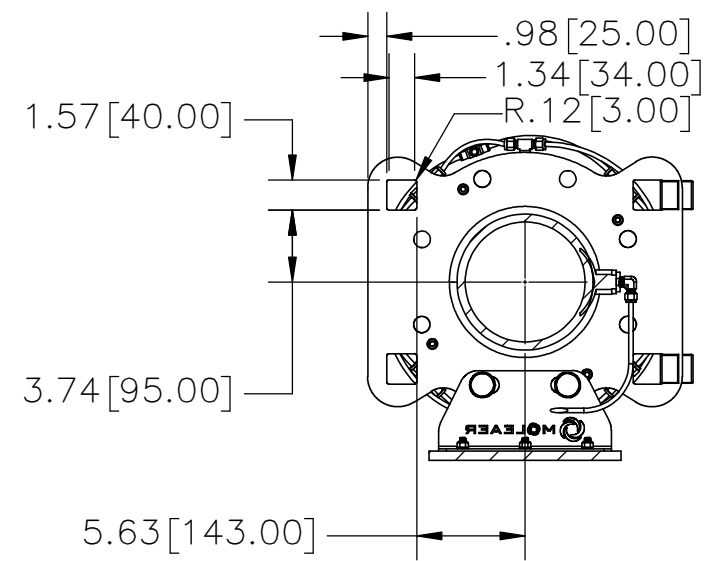
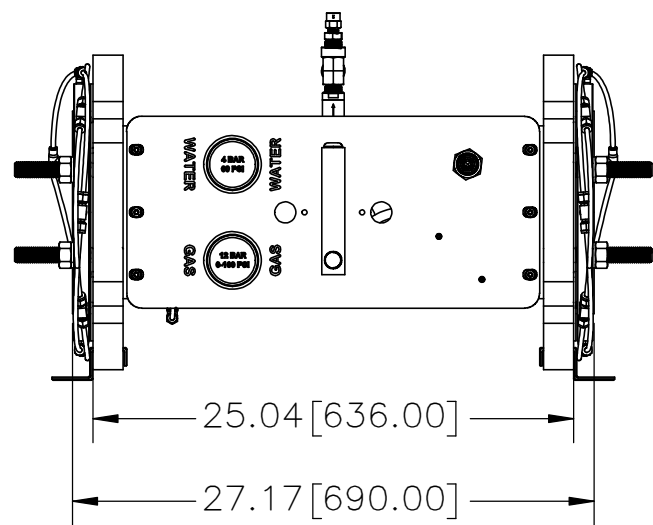
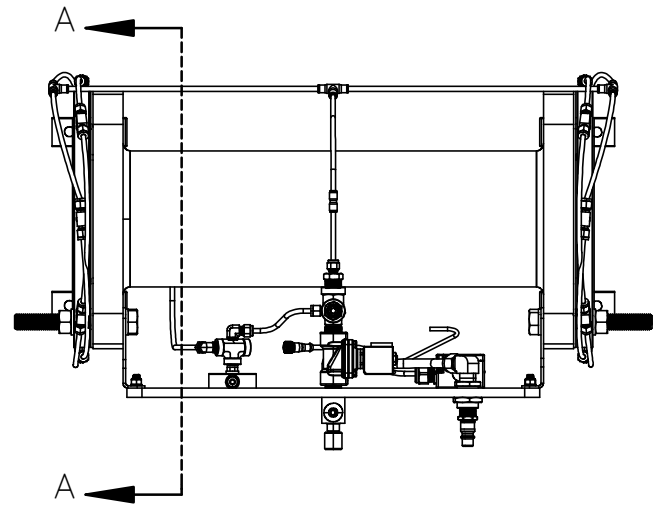
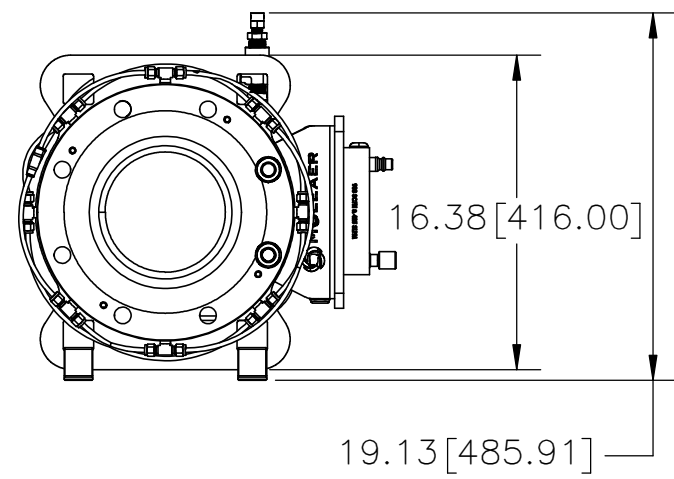
NOTE :  
ALL DIMENSIONS ARE IN INCHES[mm]



UNLESS OTHERWISE SPECIFIED:  DIMENSIONS IN INCHES[mm] TOLERANCES ARE $\pm 0.250 [\pm 6.35]$	DRAWN BY M.CHA	DATE 10/26/23	 3232 W. EL SEGUNDO BLVD HAWTHORNE CA, 90250 DRAWING TITLE: <b>NBG 6, HDPE, METRIC, GAD</b> DRAWING NO: <b>50F2-800</b>
	CHECKED BY P.MAHMOUDIAN	DATE 11/27/23	
	APPROVED BY P.MAHMOUDIAN	DATE 11/27/23	
<b>PROPRIETARY AND CONFIDENTIAL</b> INFORMATION CONTAINED IN THIS DRAWING IS THE SOLE PROPERTY OF "MOLEAER INC". ANY REPRODUCTION IN PART OR WHOLE WITHOUT THE WRITTEN PERMISSION OF "MOLEAER INC" IS PROHIBITED.			  SIZE: B SCALE: 1:10 SHEET: 2/2 REV: B