

MATERIAL LIST

MAIN COMPONENT	MATERIAL
PIPES	HDPE
GAUGES	300 SERIES STAINLESS STEEL
GAS TUBING	PTFE
SOLENOID VALVE	316SS

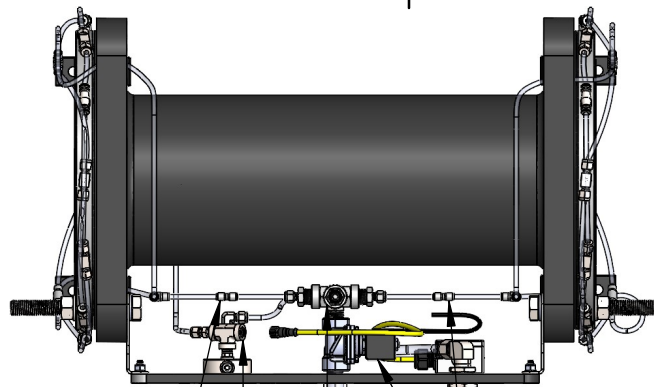

CHECK VALVE, PVC
 WATER PRESSURE SWITCH SET : 0.35 BAR (5 PSI)
 CHECK VALVE, 316SS

CHECK VALVE, PVC
 SOLENOID VALVE

WATER PRESSURE GAUGE
 0-4 BAR (0-60 PSI)

CIP PORT: 1/4 MNPT

GAS INLET: 1/2" INDUSTRIAL FITTING

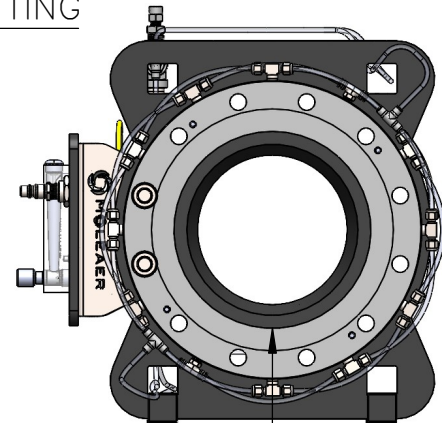
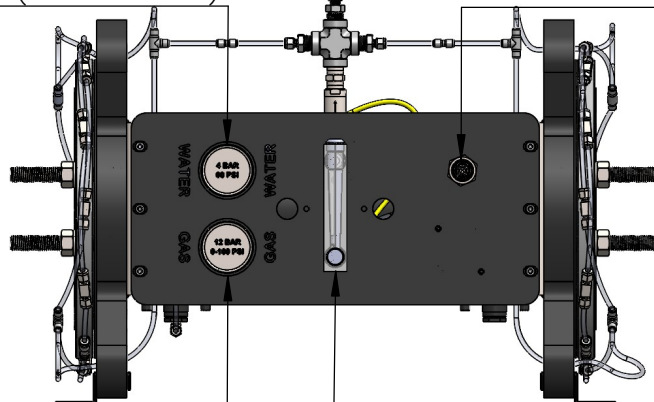
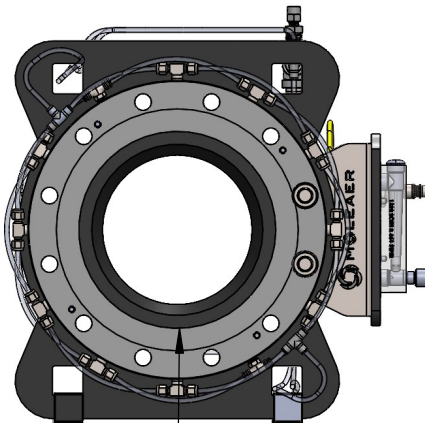

GAS PRESSURE GAUGE
 0-12 BAR (0-160 PSI)

ROTAMETER: 1380SCFH & 651SLPM

JUNCTION BOX
 BLK : +
 WHT : -

WATER INLET : D250mm

WATER OUTLET : D250mm

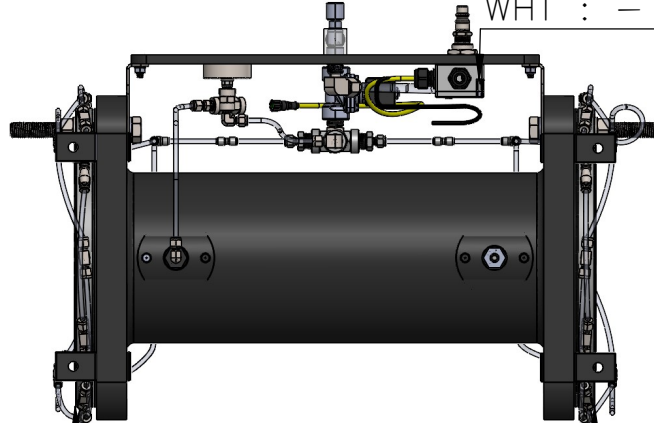

DN250 PN10 FLANGE

DN250 PN10 FLANGE

REV.	BY	DESCRIPTION	ECO	DATE	CHECKED	APPROVED
B	EC	ADDED CHECK VALVES & CIP PORT	2069	02/28/24	MC	PM
A	MC	INITIAL RELEASE	2040	10/30/23	PM	PM

REVISIONS

UNLESS OTHERWISE SPECIFIED: DIMENSIONS IN INCHES[mm] TOLERANCES ARE ±0.250[±6.35]	DRAWN BY M.CHA	DATE 10/30/23
	CHECKED BY P.MAHMOUDIAN	DATE 11/28/23
	APPROVED BY P.MAHMOUDIAN	DATE 11/28/23
PROPRIETARY AND CONFIDENTIAL INFORMATION CONTAINED IN THIS DRAWING IS THE SOLE PROPERTY OF "MOLEAER INC". ANY REPRODUCTION IN PART OR WHOLE WITHOUT THE WRITTEN PERMISSION OF "MOLEAER INC" IS PROHIBITED.		

3232 W. EL SEGUNDO BLVD HAWTHORNE CA, 90250
DRAWING TITLE: NBG 8, HDPE, METRIC
DRAWING NO: 50F1-900
SIZE: B SCALE: 1:10 SHEET: 1/2 REV: B

NOTE :
ALL DIMENSIONS ARE IN INCHES[mm]

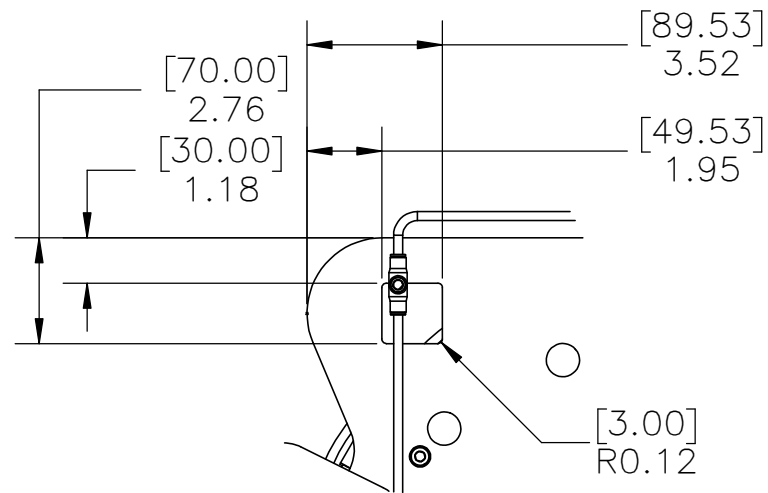

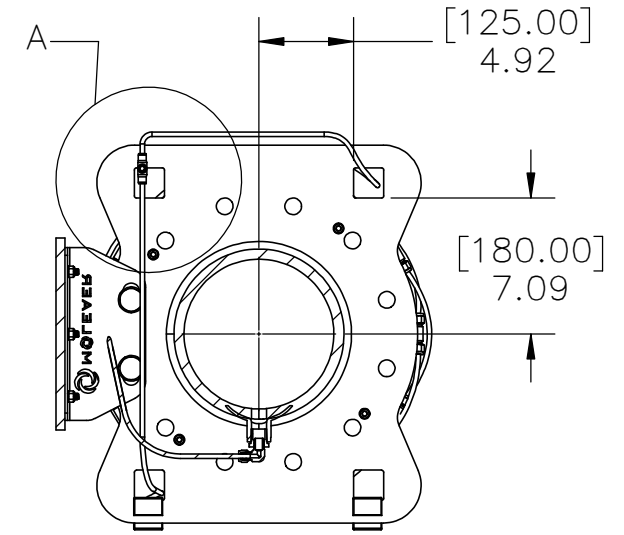
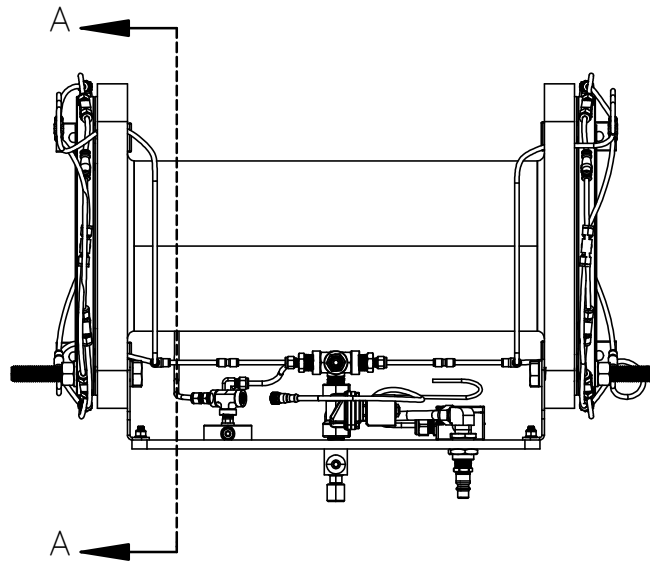

DETAIL A
SCALE 1 : 5

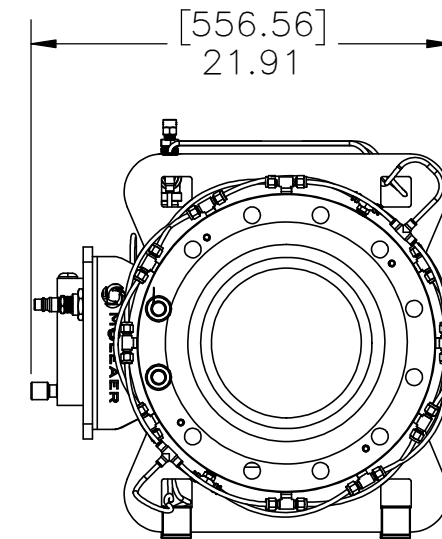
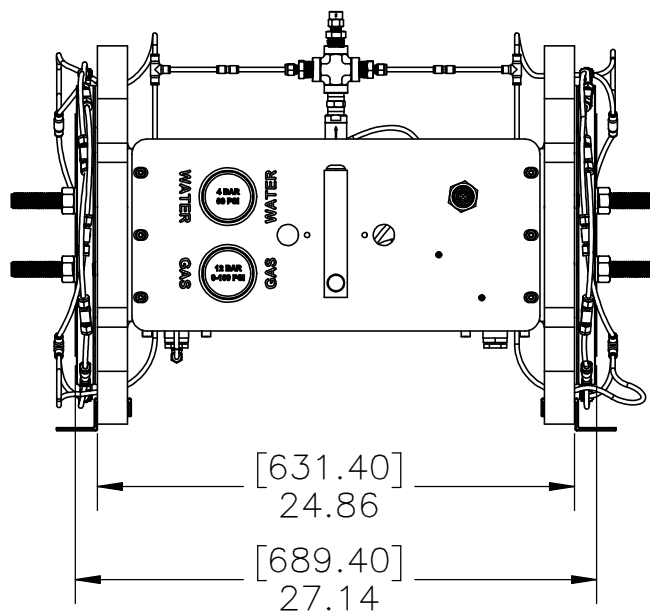
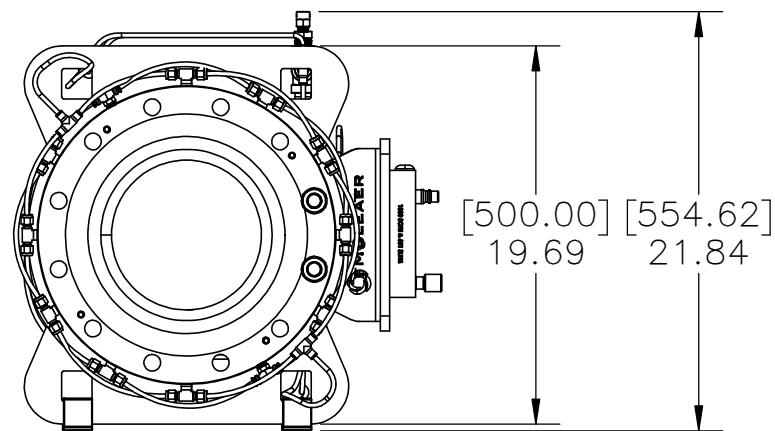

SECTION A-A



UNLESS OTHERWISE SPECIFIED: DIMENSIONS IN INCHES[mm] TOLERANCES ARE $\pm 0.250[\pm 6.35]$	DRAWN BY M.CHA	DATE 10/30/23	 MOLEAER <small>ADVANCING NANOMOBILE TECHNOLOGY</small> 3232 W. EL SEGUNDO BLVD HAWTHORNE CA, 90250	
	CHECKED BY P.MAHMOUDIAN	DATE 11/28/23		DRAWING TITLE: NBG 8, HDPE, METRIC
	APPROVED BY P.MAHMOUDIAN	DATE 11/28/23		DRAWING NO: 50F1-900
PROPRIETARY AND CONFIDENTIAL INFORMATION CONTAINED IN THIS DRAWING IS THE SOLE PROPERTY OF "MOLEAER INC". ANY REPRODUCTION IN PART OR WHOLE WITHOUT THE WRITTEN PERMISSION OF "MOLEAER INC" IS PROHIBITED.			  SIZE: B SCALE: 1:10 SHEET: 2/2 REV: B	