

MATERIAL LIST

MAIN COMPONENTS	MATERIAL
PIPES	HDPE
GAUGE	300 SERIES STAINLESS STEEL
GAS TUBING	PTFE
SOLENOID VALVE	316SS

CIP PORT: 1/4 MNPT

CHECK VALVE, PVC

CHECK VALVE, 316SS

GAS INLET: 1/2" NPT INDUSTRIAL FITTING
 WATER PRESSURE SWITCH : 0.35 BAR (5 PSIG)
 WATER PRESSURE GAUGE 0-4 BAR (0-60PSI)

ROTAMETER RANGE : 480SCFH & 227SLPM

GAS PRESSURE GAUGE 0-12BAR (0-160 PSI)

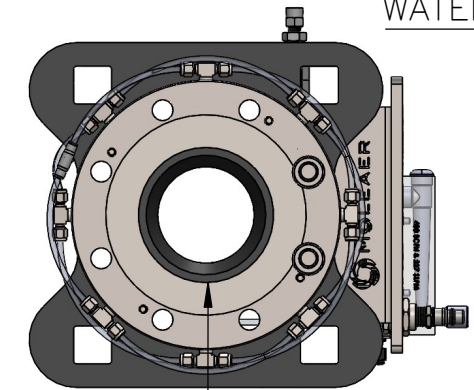

WATER INLET : D150mm

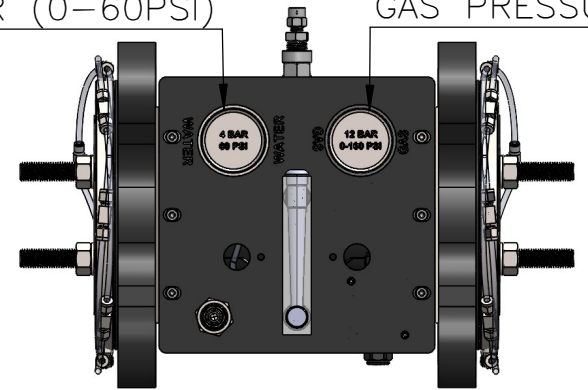

SOLENOID VALVE
 JUNCTION BOX
 BLK : +
 WHT : -

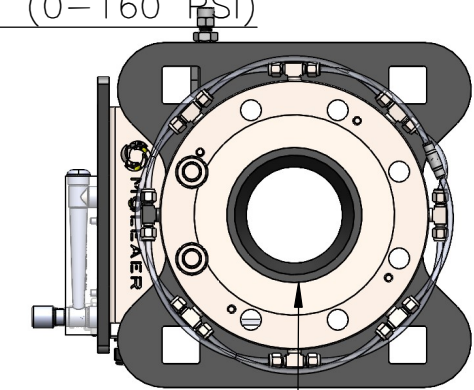

WATER OUTLET : D150mm

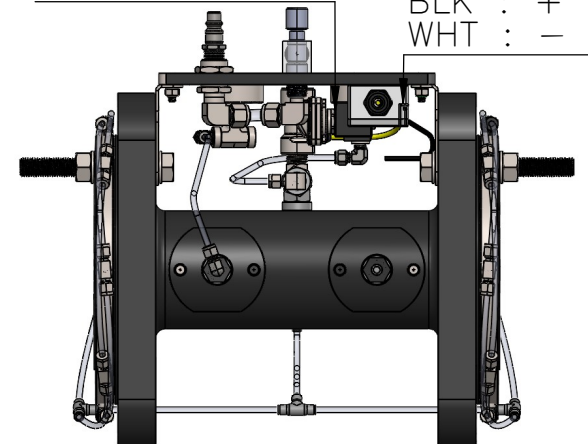
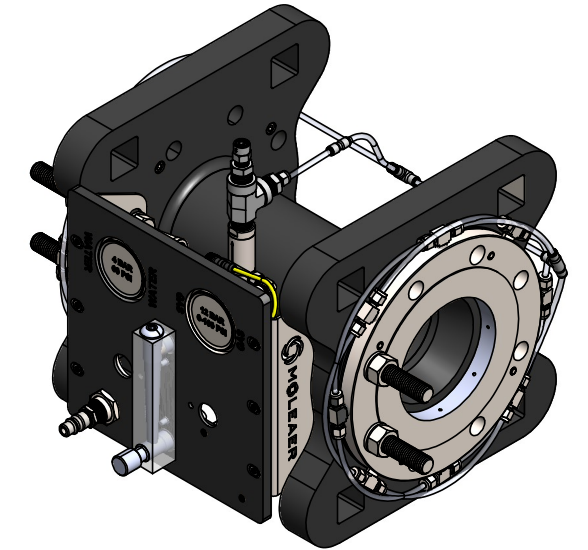

REV.	BY	DESCRIPTION	ECO	DATE	CHECKED	APPROVED
B	EC	ADDED CHECK VALVES & CIP PORT	2069	02/23/24	MC	PM
A	MC	INITIAL RELEASE	2040	10/23/23	PM	PM

REVISIONS

UNLESS OTHERWISE SPECIFIED:	DRAWN BY M.CHA	DATE 10/23/23
DIMENSIONS IN INCHES[mm]	CHECKED BY P.MAHMOUDIAN	DATE 11/22/23
TOLERANCES ARE ±0.250[±6.35]	APPROVED BY P.MAHMOUDIAN	DATE 11/22/23
PROPRIETARY AND CONFIDENTIAL INFORMATION CONTAINED IN THIS DRAWING IS THE SOLE PROPERTY OF "MOLEAER INC". ANY REPRODUCTION IN PART OR WHOLE WITHOUT THE WRITTEN PERMISSION OF "MOLEAER INC" IS PROHIBITED.		

3232 W. EL SEGUNDO BLVD
 HAWTHORNE CA, 90250
 DRAWING TITLE:
NBG 4, HDPE, METRIC, GAD
 DRAWING NO:
50F0-701

SIZE: B SCALE: 1:10 SHEET: 1/2 REV: B

NOTE:
ALL DIMENSIONS ARE IN INCHES[mm]

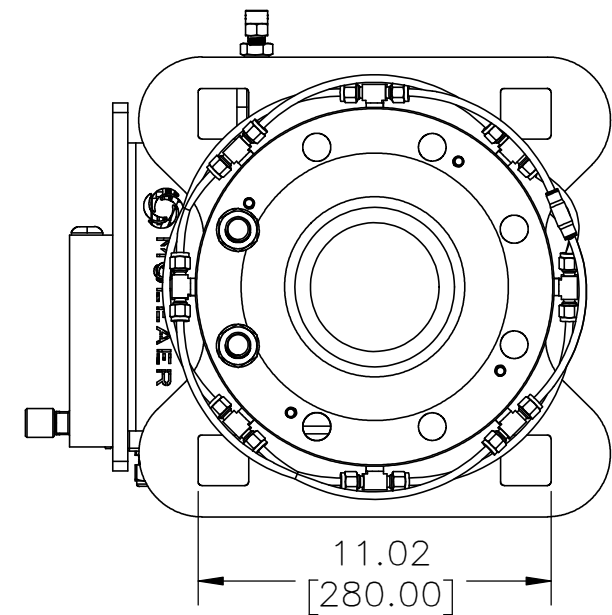
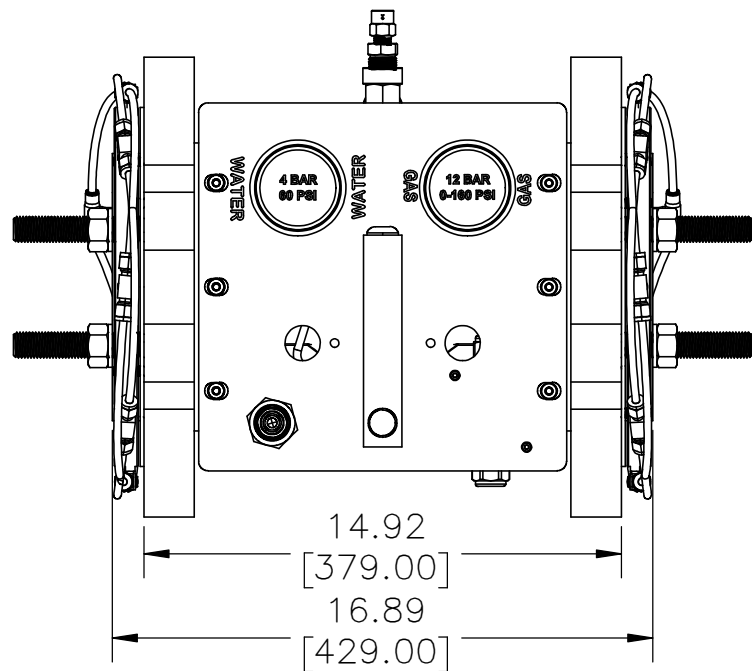
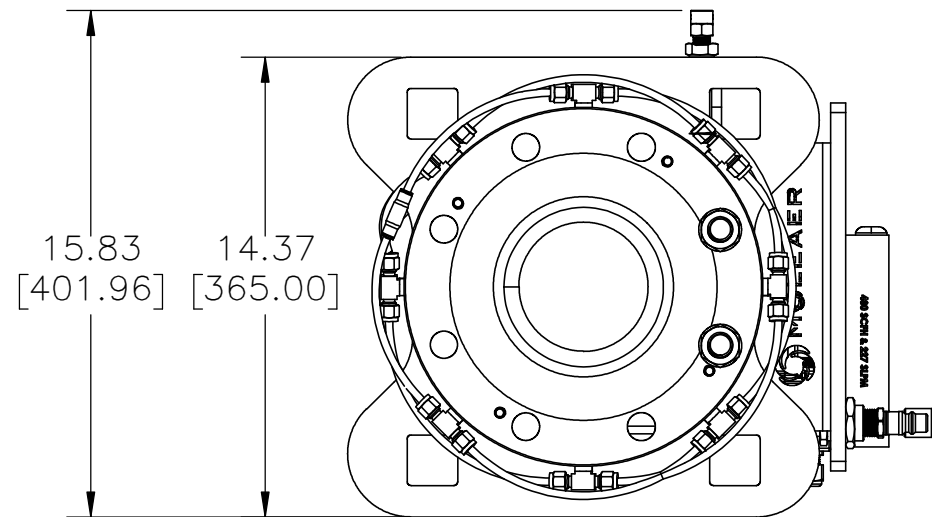
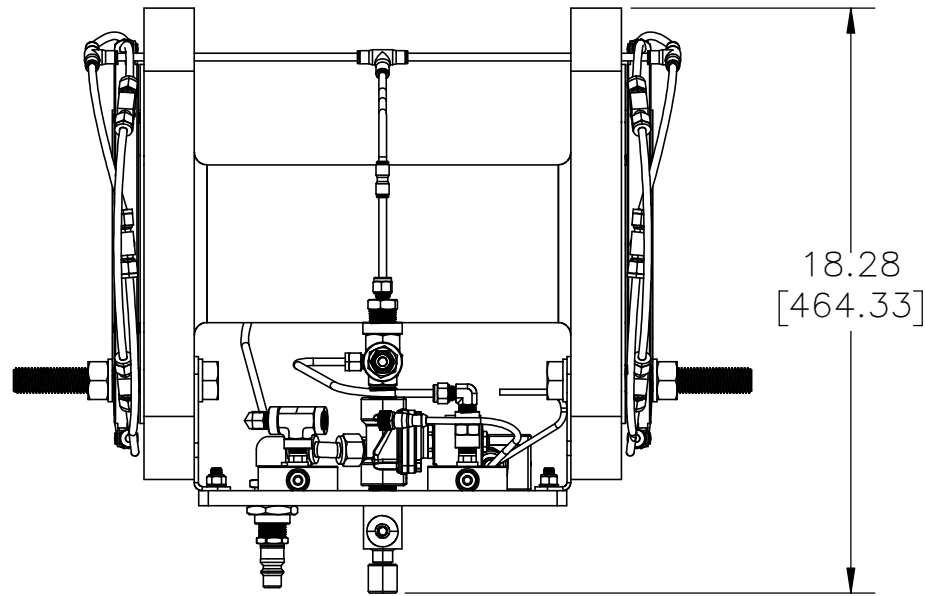

UNLESS OTHERWISE SPECIFIED: DIMENSIONS IN INCHES[mm] TOLERANCES ARE ± 0.250 [± 6.35]	DRAWN BY M.CHA	DATE 10/23/23	 3232 W. EL SEGUNDO BLVD HAWTHORNE CA, 90250 DRAWING TITLE: NBG 4, HDPE, METRIC, GAD DRAWING NO: 50FO-701
	CHECKED BY P.MAHMOUDIAN	DATE 11/22/23	
	APPROVED BY P.MAHMOUDIAN	DATE 11/22/23	
PROPRIETARY AND CONFIDENTIAL INFORMATION CONTAINED IN THIS DRAWING IS THE SOLE PROPERTY OF "MOLEAER INC". ANY REPRODUCTION IN PART OR WHOLE WITHOUT THE WRITTEN PERMISSION OF "MOLEAER INC" IS PROHIBITED.			SIZE: B SCALE: 1:10 SHEET: 2/2 REV: B