

MATERIAL LIST

MAIN COMPONENT	MATERIAL
PIPES	316SS
GAUGE	300 SERIES STAINLESS STEEL
GAS TUBING	PTFE
SOLENOID VALVE	316SS

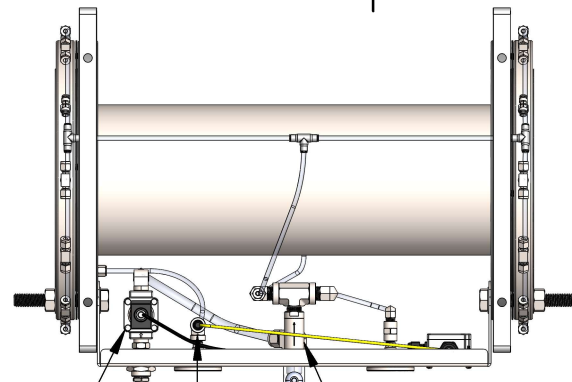

SOLENOID VALVE

GAS CHECK VALVE

GAS INLET : 1/2" NPT INDUSTRIAL FITTING OR CGA022

WATER PRESSURE SWITCH : 0.35 BAR (5 PSIG)

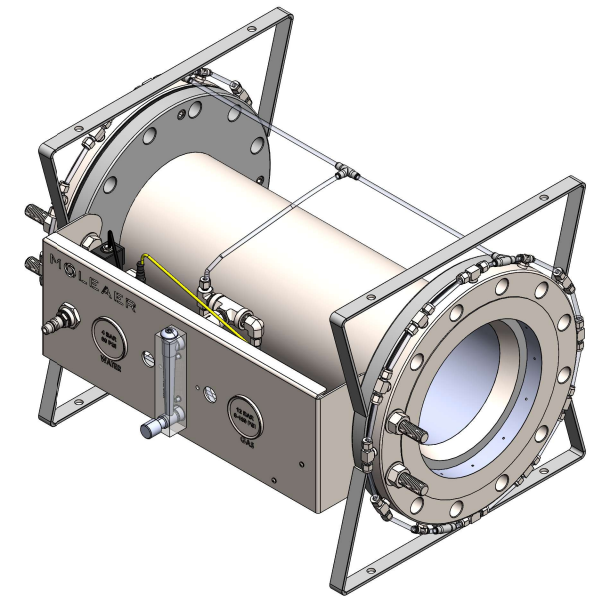

WATER PRESSURE GAUGE
0-4 BAR (0-60 PSI)

GAS PRESSURE GAUGE
0-12 BAR (0-160 PSI)

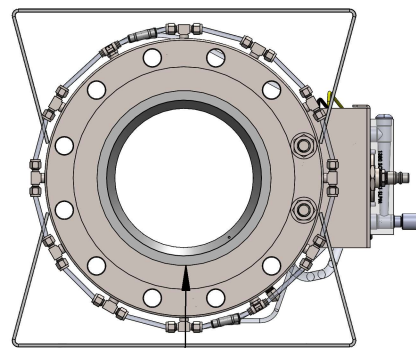

WATER INLET : 8"

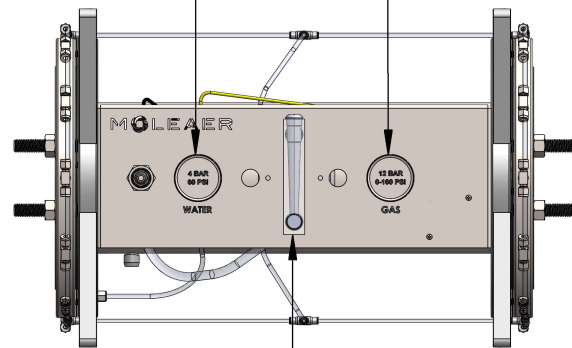

ROTAMETER RANGE 1380SCFH & 651SLPM

JUNCTION BOX
24VDC
BLK : +
WHT : -

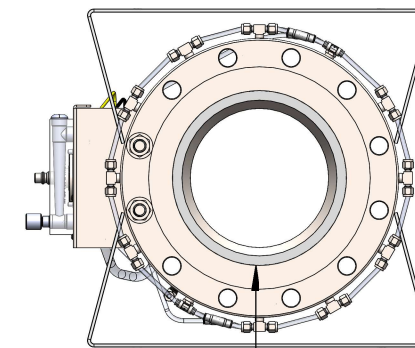

WATER OUTLET : 8"

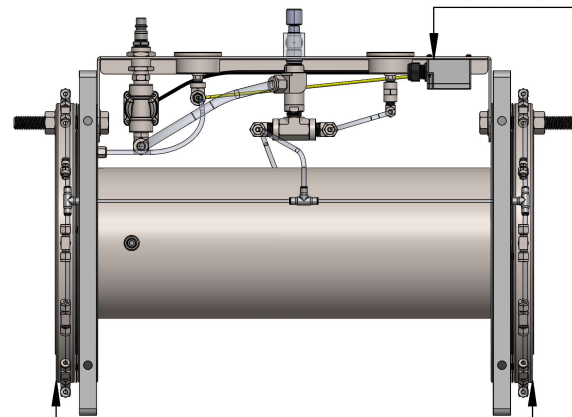

ENTRY FLANGE 10" ANSI 150

EXIT FLANGE 10" ANSI 150

REV.	BY	DESCRIPTION	ECO	DATE	CHECKED	APPROVED
A	EC	INITIAL RELEASE	2023	10/30/23	MC	PM
REVISIONS						

UNLESS OTHERWISE SPECIFIED:		
DIMENSIONS IN INCHES	DRAWN BY E.CRUIZ	DATE 10/30/23
TOLERANCES ARE ±0.250	CHECKED BY M.CHA	DATE 12/01/23
	APPROVED BY P.MAHMOUDIAN	DATE 12/04/23

 <small>ADVANCING NANOSURFACIAL TECHNOLOGY</small>	3232 W. EL SEGUNDO BLVD HAWTHORNE CA, 90250	
	DRAWING TITLE:	
	NBG 8, 316SS, IMPERIAL, GAD	
DRAWING NO:		50F1-607

PROPRIETARY AND CONFIDENTIAL
 INFORMATION CONTAINED IN THIS DRAWING IS THE SOLE PROPERTY OF "MOLEAER INC". ANY REPRODUCTION IN PART OR WHOLE WITHOUT THE WRITTEN PERMISSION OF "MOLEAER INC" IS PROHIBITED.

		SIZE: B	SCALE: 1:10	SHEET: 1/2	REV: A
--	--	---------	-------------	------------	--------

8 7 6 5 4 3 2 1

F

E

D

C

B

A

8 7 6 5 4 3 2 1

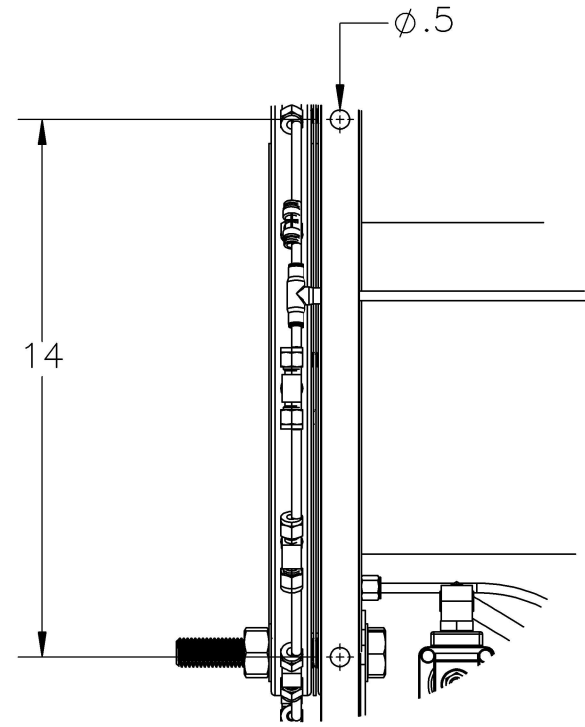

DETAIL A

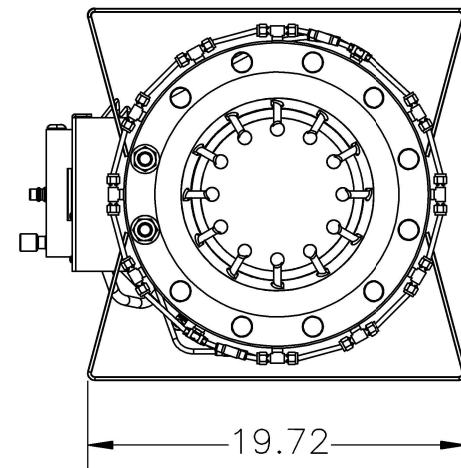
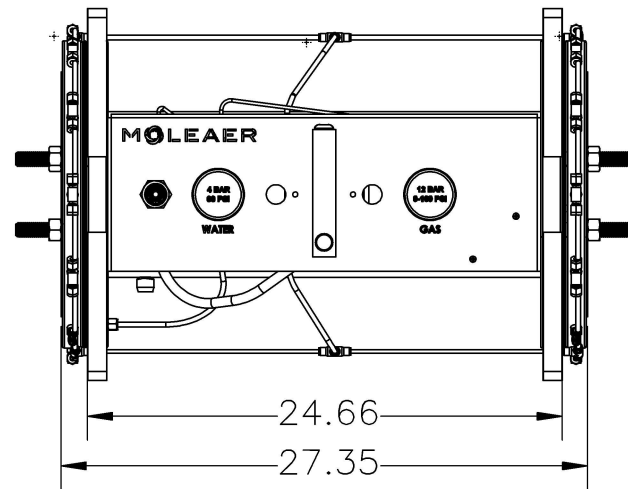
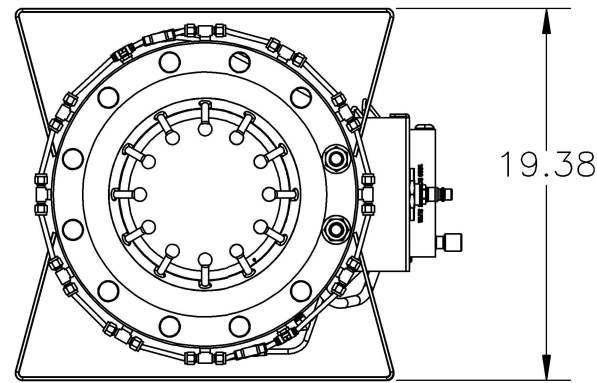
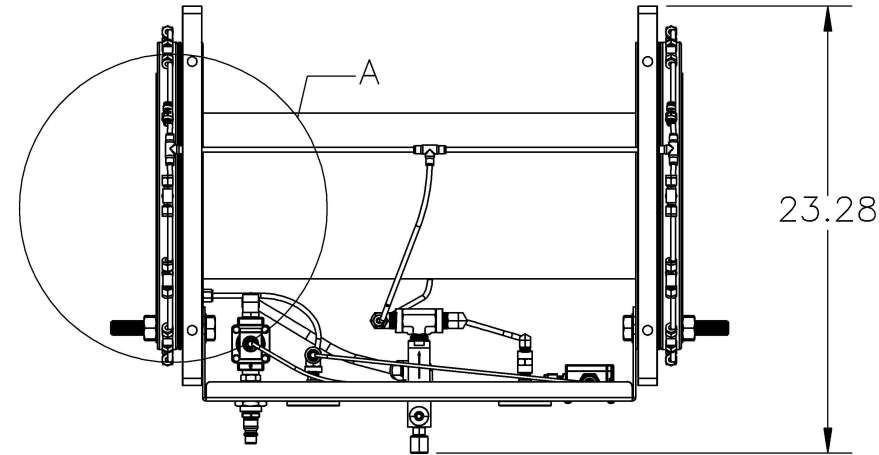

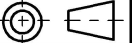
UNLESS OTHERWISE SPECIFIED: DIMENSIONS IN INCHES TOLERANCES ARE ±0.250	DRAWN BY E.CRUIZ	DATE 10/30/23	 MOLEAER <small>ADVANCING NANOSURFACIAL TECHNOLOGY</small> 3232 W. EL SEGUNDO BLVD HAWTHORNE CA, 90250	
	CHECKED BY M.CHA	DATE 12/01/23		
	APPROVED BY P.MAHMOUDIAN	DATE 12/04/23		
PROPRIETARY AND CONFIDENTIAL INFORMATION CONTAINED IN THIS DRAWING IS THE SOLE PROPERTY OF "MOLEAER INC". ANY REPRODUCTION IN PART OR WHOLE WITHOUT THE WRITTEN PERMISSION OF "MOLEAER INC" IS PROHIBITED.			DRAWING TITLE: NBG 8, 316SS, IMPERIAL, GAD DRAWING NO: 50F1-607	
 SIZE: B		SCALE: 1:10	SHEET: 2/2	REV: A

REV.	BY	DESCRIPTION	ECO	DATE	CHECKED	APPROVED
A	EC	INITIAL RELEASE	2023	10/30/23	MC	PM
REVISIONS						