

MATERIAL LIST

PIPES	316SS
GAUGE	300 SERIES STAINLESS STEEL
GAS TUBING	PTFE
SOLENOID VALVE	316SS

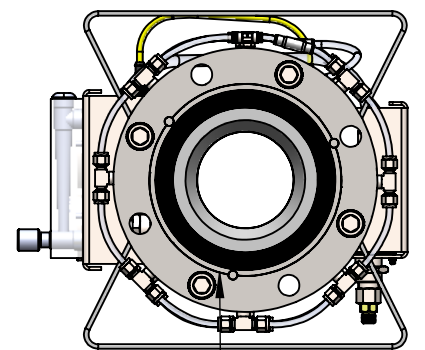
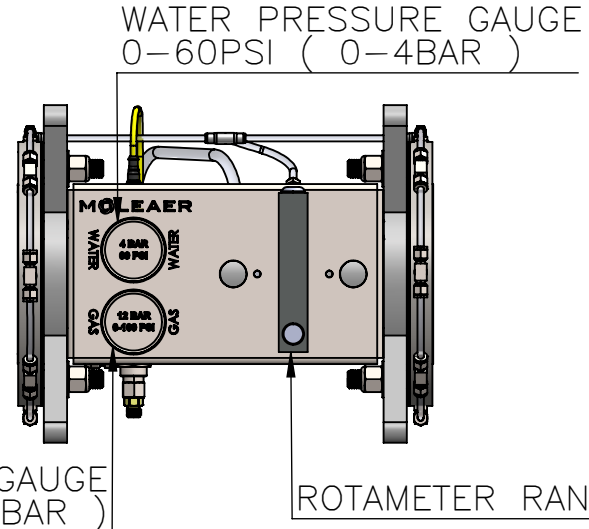
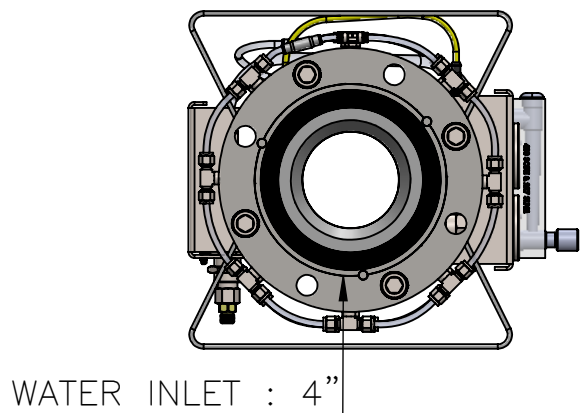
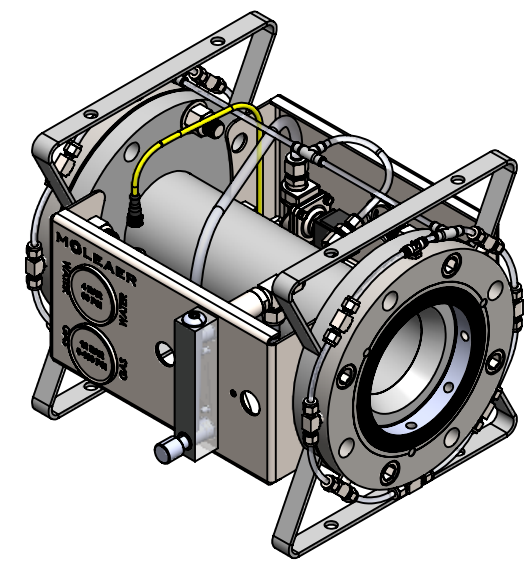
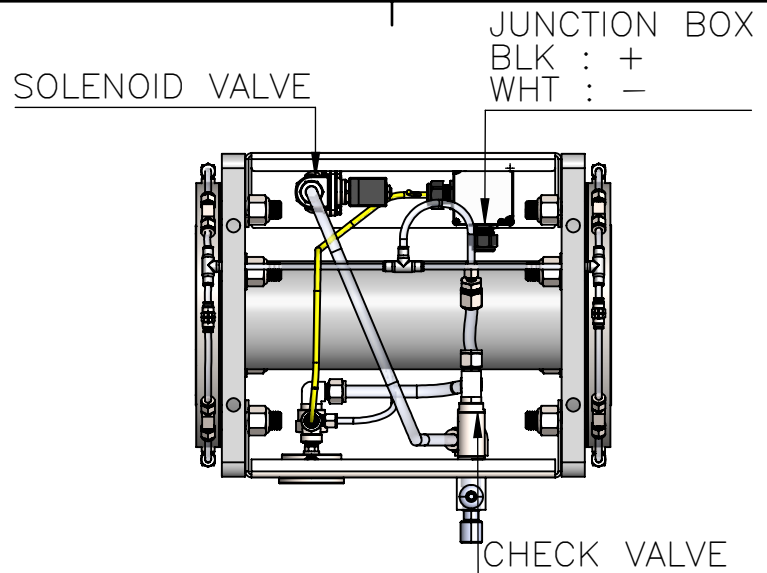

ENTRY FLANGE 6" ANSI #150

EXIT FLANGE 6" ANSI #150

GAS INLET : CGA022 OR 1/2" NPT INDUSTRIAL FITTING

UNLESS OTHERWISE SPECIFIED: DIMENSIONS IN INCHES[mm] TOLERANCES ARE ±0.250[±6.35]	DRAWN BY M.CHA	DATE 08/23/23
	CHECKED BY P.MAHMOUDIAN	DATE 10/06/23
	APPROVED BY P.AMHMOUDIAN	DATE 10/06/23
PROPRIETARY AND CONFIDENTIAL INFORMATION CONTAINED IN THIS DRAWING IS THE SOLE PROPERTY OF "MOLEAER INC". ANY REPRODUCTION IN PART OR WHOLE WITHOUT THE WRITTEN PERMISSION OF "MOLEAER INC" IS PROHIBITED.		

MOLEAER 3232 W. EL SEGUNDO BLVD
HAWTHORNE CA, 90250

DRAWING TITLE:
NBG 4, 316SS, IMPERIAL, GAD

DRAWING NO:
50F1-110

SIZE: B SCALE: 1:50 SHEET: 1/2 REV: A

REV.	BY	DESCRIPTION	ECO	DATE	CHECKED	APPROVED
A	MC	INITIAL RELEASE	2023	08/23/23	PM	PM
REVISIONS						

NOTE :
ALL DIMENSIONS ARE IN INCHES.

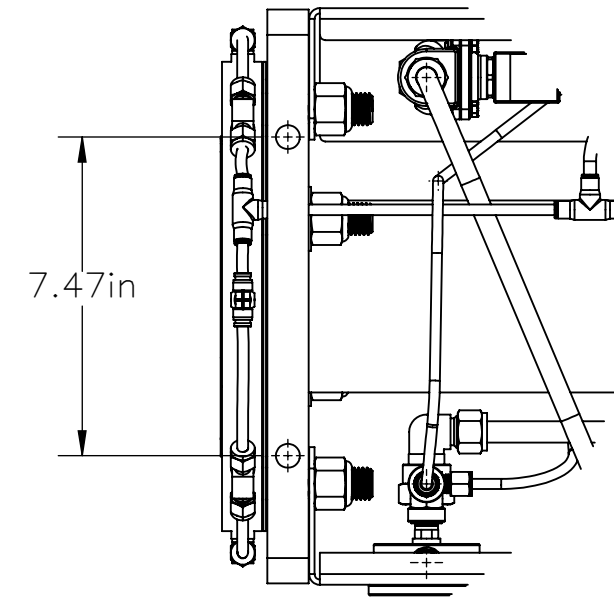
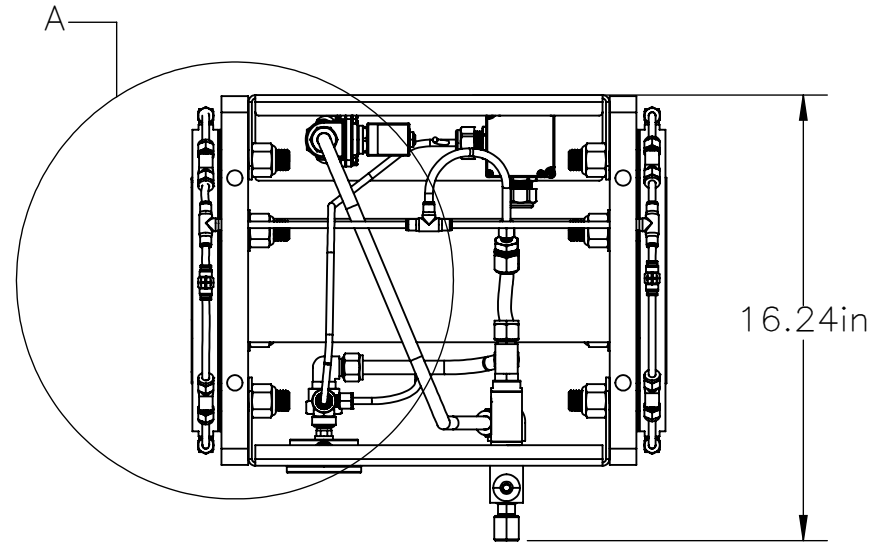

DETAIL A
SCALE 2 : 9

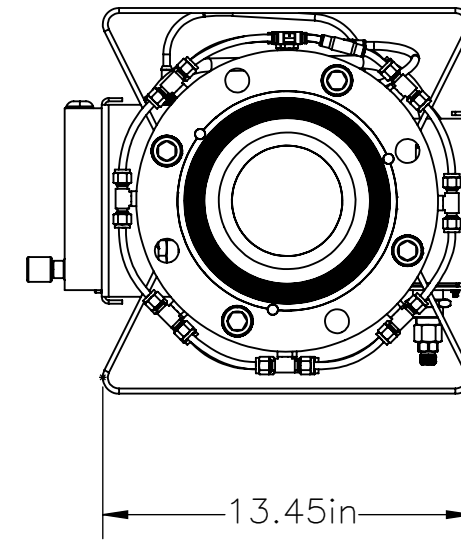
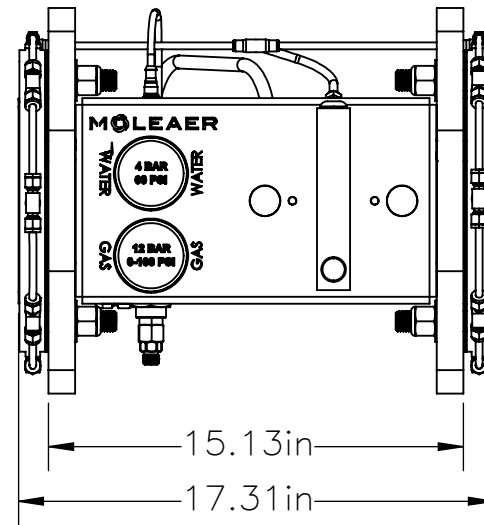
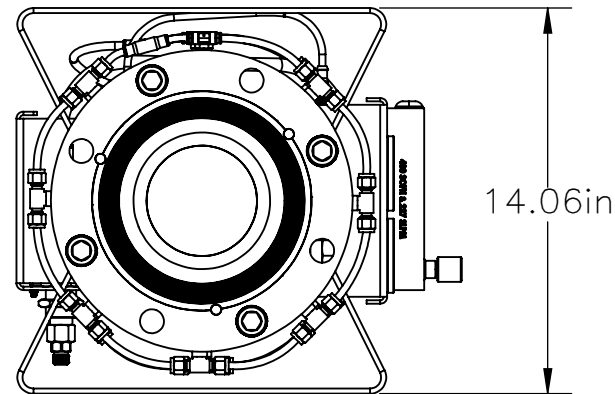

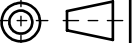
UNLESS OTHERWISE SPECIFIED: DIMENSIONS IN INCHES[mm] TOLERANCES ARE $\pm 0.250[\pm 6.35]$	DRAWN BY M.CHA	DATE 08/23/23	 3232 W. EL SEGUNDO BLVD HAWTHORNE CA, 90250 DRAWING TITLE: NBG 4, 316SS, IMPERIAL, GAD DRAWING NO: 50F1-110
	CHECKED BY P.MAHMOUDIAN	DATE 10/06/23	
	APPROVED BY P.AMHMOUDIAN	DATE 10/06/23	
PROPRIETARY AND CONFIDENTIAL INFORMATION CONTAINED IN THIS DRAWING IS THE SOLE PROPERTY OF "MOLEAER INC". ANY REPRODUCTION IN PART OR WHOLE WITHOUT THE WRITTEN PERMISSION OF "MOLEAER INC" IS PROHIBITED.			 SIZE: B SCALE: 1:50 SHEET: 2/2 REV: A

REV.	BY	DESCRIPTION	ECO	DATE	CHECKED	APPROVED
A	MC	INITIAL RELEASE	2023	08/23/23	PM	PM
REVISIONS						