



MOLEAER[®]
ADVANCING NANOBUBBLE TECHNOLOGY

MOLEAER BLOOM 1.5 NANOBUBBLE GENERATOR

Operation and Maintenance Instructions

IMPORTANT SAFETY INSTRUCTIONS
READ AND FOLLOW ALL INSTRUCTIONS
SAVE THESE INSTRUCTIONS

CUSTOMER SERVICE / TECHNICAL SUPPORT
If you have questions or need to order
Moleaer, Inc. replacement parts and
products, please use the following contact
information:

CUSTOMER SERVICE:
Monday to Friday: 8:00 a.m. to 5:00 p.m.
PST
Phone: +1 (424) 558-3567
Email: info@moleaer.com

WEBSITE:
www.moleaer.com

Table of Contents

Safety Instructions	3
Important Notice	3
Attention Installer	3
Attention User.....	3
Risk of Electrical Shock.....	3
General Warnings	3
Suction Entrapment Hazard	4
Information About the System	5
Gas - Specifications	5
Gas Connection.....	5
Gas Flow and Pressure.....	5
Gas Pressure Switch and Low Pressure Warning Light	6
System Operation	6
Automatic Operation	7
Controller Operation (Bloom IQ Only).....	7
Bloom IQ Timer Mode	8
Changing Setpoints	8
Menu Navigation	8
Continuous Operation	9
Intermittent Operation (Standard Bloom Only).....	10
Pump Maintenance	10
Pump Strainer Basket Care	10
Cleaning the Pump Strainer Basket.....	10
Winterizing.....	11
Motor Care	11
Shaft Seal Replacement	11
Pump Disassembly	12
Pump Reassembly	12
Restart Instructions	12
Priming the Pump.....	13
Cleaning and Sanitizing	13
General Cleaning Procedures.....	13
Safety Precautions	14
Troubleshooting Guide	15

Pump Performance Curves	18
Limited Warranty	19
Warranty	19
Claims; Exclusive Remedy	19
Limited Warranty	19
Document Revision History	20

Safety Instructions

Important Notice



This guide provides operation and maintenance instructions for this product. Consult Moleaer with any questions regarding this equipment.

Attention Installer

This guide contains important information about the operation, maintenance, and safe use of this product. This information should be given to the owner and / or operator of this equipment after installation. This Bloom nanobubble generator is for **INDOOR USE ONLY**. If it must be installed outside, a minimum coverage is a full roof.

Attention User

This manual contains important information that will help you in operating and maintaining this product. Please retain it for future reference. Warnings and safety instructions for Moleaer Bloom Nanobubble Generators and other related products are available at <http://www.moleaer.com> or call U.S. +1 (424) 558-3567 for additional free copies of these instructions.

READ AND FOLLOW ALL INSTRUCTIONS. SAVE THESE INSTRUCTIONS.



This is the safety alert symbol. When you see this symbol, on your system or in this manual, look for one of the following signal words and be alert to the potential for personal injury.



Warns about hazards that can cause death, serious personal injury, or major property damage if ignored.



Warns about hazards that may or can cause minor personal injury or property damage if ignored.

NOTE

Indicates special instructions not related to hazards. Carefully read and follow all safety instructions in this manual and on equipment. Keep safety labels in good condition; replace if missing or damaged.

When installing and using this electrical equipment, basic safety precautions should always be followed, including the following:

Risk of Electrical Shock

Connect only to a branch circuit protected by a ground-fault circuit interrupter (GFCI). Contact a qualified electrician if you cannot verify that the circuit is protected by a GFCI.

This unit must be connected only to a supply circuit that is protected by a ground-fault circuit interrupter (GFCI). The GFCI should be provided by the installer and should be tested on a routine basis. To test the GFCI, push the test button. The GFCI should interrupt power. Push the reset button. Power should be restored. If the GFCI fails to operate in this manner, the GFCI is defective. If the GFCI interrupts power to the pump without the test button being pushed, a ground current is flowing, indicating the possibility of an electric shock. Do not use this pump. Disconnect the pump and have the problem corrected by a qualified service representative before using.

General Warnings

Never open the inside of the pump drive motor enclosure. There is a capacitor bank that holds a 230 VAC charge, even when there is no power to the unit.

The Bloom pump is capable of high flow rates; use caution when installing and programming to limit pump's performance potential with old or questionable equipment.

Before servicing the pump switch OFF power to the pump by disconnecting the main circuit to the Bloom generator.

This product is not intended for use by persons (including children) of reduced physical, sensory or mental capabilities, or lack of experience and knowledge, unless they have been given supervision or instruction concerning the use of the appliance by a person responsible for their safety.



FAILURE TO FOLLOW ALL INSTRUCTIONS AND WARNINGS CAN RESULT IN SERIOUS BODILY INJURY OR DEATH. THIS PUMP SHOULD BE INSTALLED AND SERVICED ONLY BY A QUALIFIED SERVICE PROFESSIONAL. INSTALLERS, OPERATORS AND OWNERS MUST READ THESE WARNINGS AND ALL INSTRUCTIONS IN THE OWNER'S MANUAL BEFORE USING THIS PUMP. THESE WARNINGS AND THE OWNER'S MANUAL MUST BE LEFT WITH THE PRODUCT OWNER.

Suction Entrapment Hazard

Stay off main drain and away from all suction outlets!



This generator produces high levels of suction and creates a strong vacuum at the main drain at the bottom of the body of water. This suction is so strong that it can trap adults or children under water if they come in close proximity to a drain or a loose or broken drain cover or grate.

⚠ DANGER

RISK OF ELECTRICAL SHOCK OR ELECTROCUTION



PUMPS REQUIRE HIGH VOLTAGE WHICH CAN SHOCK, BURN, OR CAUSE DEATH.

BEFORE WORKING ON THE CLEAR PUMP, always disconnect power to the pump at the circuit breaker from the pump before servicing the pump. Failure to do so could result in death or serious injury to service person, system users, or others due to electric shock.

NOTE: All suction plumbing must be installed in accordance with the latest national and local codes, standards, and guidelines.

⚠ WARNING

A clearly labeled emergency shutoff switch for the equipment must be in an easily accessible, obvious place. Make sure users know where it is and how to use it in case of emergency.

⚠ CAUTION

This equipment has been evaluated for use with water only.

⚠ CAUTION

Before operation, be sure to completely rinse the pump volute with water.

⚠ WARNING

RISK OF ELECTRICAL SHOCK

This pump is supplied with a grounding conductor and grounding type attachment plug. To reduce the risk of electric shock, be certain that it is connected only to a properly grounded, grounding-type receptacle.

⚠ WARNING

Pumps improperly sized or installed or used in applications other than for which the pump was intended can result in severe personal injury or death. These risks may include but not be limited to electric shock, fire, flooding, suction entrapment or severe injury or property damage caused by a structural failure of the pump or other system component.

⚠ WARNING

The pump can produce high levels of suction within the suction side of the plumbing system. These high levels of suction can pose a risk if a person comes within the proximity of the suction openings. A person can be seriously injured by this high level of vacuum or may become trapped and drown. It is absolutely critical that the suction plumbing be installed in accordance with the latest national and local codes for aquaculture systems.

⚠ DANGER



HAZARDOUS PRESSURE. STAND CLEAR OF PUMP AND FILTER DURING STARTUP. CIRCULATION SYSTEMS OPERATE UNDER HIGH PRESSURE. WHEN ANY PART OF THE CIRCULATING SYSTEM (I.E. LOCKING RING, PUMP, FILTER, VALVES, ETC.) IS SERVICED, AIR CAN ENTER THE SYSTEM AND BECOME PRESSURIZED. PRESSURIZED AIR CAN CAUSE THE PUMP HOUSING COVER, FILTER LID AND VALVES TO VIOLENTLY SEPARATE WHICH CAN RESULT IN SEVERE PERSONAL INJURY OR DEATH. FILTER TANK LID AND STRAINER COVER MUST BE PROPERLY SECURED TO PREVENT VIOLENT SEPARATION. STAND CLEAR OF ALL CIRCULATION SYSTEM EQUIPMENT WHEN TURNING ON OR STARTING UP PUMP. BEFORE SERVICING EQUIPMENT, MAKE NOTE OF THE FILTER PRESSURE. BE SURE THAT ALL CONTROLS ARE SET TO ENSURE THE SYSTEM CANNOT INADVERTENTLY START DURING SERVICE. TURN OFF ALL POWER TO THE PUMP.

IMPORTANT: PLACE FILTER MANUAL AIR RELIEF VALVE IN THE OPEN POSITION AND WAIT FOR ALL PRESSURE IN THE SYSTEM TO BE RELIEVED. BEFORE STARTING THE SYSTEM, FULLY OPEN THE MANUAL AIR RELIEF VALVE AND PLACE ALL SYSTEM VALVES IN THE "OPEN" POSITION TO ALLOW WATER TO FLOW FREELY FROM THE TANK AND BACK TO THE TANK. STAND CLEAR OF ALL EQUIPMENT AND START THE PUMP. IMPORTANT: DO NOT CLOSE FILTER MANUAL AIR RELIEF VALVE UNTIL ALL PRESSURE HAS BEEN DISCHARGED FROM THE VALVE AND A STEADY STREAM OF WATER APPEARS. OBSERVE FILTER PRESSURE GAUGE AND BE SURE IT IS NOT HIGHER THAN THE PRE-SERVICE CONDITION.

Information About the System

The Moleaer Bloom product is a nanobubble gas-injection technology tailor-made for the horticulture market. Its principle function is to alter the economics of using oxygen to improve the quality of irrigation water, promote plant growth and suppress disease. With simplicity and near perfect efficiency, the Bloom nanobubble generator super saturates irrigation water with dissolved oxygen and trillions of negatively charged nanobubbles. These tiny bubbles, about 100x smaller than a red blood cell, have several unique physical properties that make them behave very different from normal bubbles. Nanobubbles are neutrally buoyant and remain stable in solution for prolonged periods of time, creating an oxygen buffer in the water. The combination of the Bloom's high oxygen transfer efficiency and stable oxygen enriched nanobubbles enable higher oxygen transfer into the root zone where oxygen enrichment plays an important role in facilitating nutrient absorption and pathogen suppression.

Models	
Bloom 25 (U.S.)	Bloom 25 (EU)
Bloom 50 (U.S.)	Bloom 50 (EU)
Bloom 150 (U.S.)	Bloom 150 (EU)



1. System Controller
2. On / Off / Auto Selector Switch
3. Power Cord

4. CGA-022 Oxygen Inlet Connection
5. System Discharge
6. Oxygen Rotameter
7. Air Pressure Gauge (160 PSI / 11 BAR)
8. Water (Pump) Pressure Gauge (60 PSI / 4 BAR)
9. Low Gas Pressure Warning Light
10. System Inlet
11. Oxygen Injection Light

Gas - Specifications

The Moleaer Bloom nanobubble generator is designed for use with compressed oxygen or ambient air.

WARNING Do NOT mix gases with this system.

WARNING All gas fittings and hoses must be maintained free from oil and lubricants.

DANGER DO NOT PERMIT SMOKING OR OPEN FLAMES IN ANY AREAS WHERE OXYGEN IS STORED OR HANDLED. THE BLOOM GENERATOR MUST BE SEPARATED FROM FLAMMABLES AND COMBUSTIBLES BY AT LEAST 20' (6 METERS) OR 1/2 HOUR FIRE WALL.

Gas Connection

Moleaer Bloom generators come with a standard CGA-022 fitting (9/16" -18 UNF female) fitting.

The Bloom is equipped with a valve that will automatically open while the system is operating and allow oxygen to flow into the system.

Gas Flow and Pressure

1. Adjust the gas regulator on the feed gas tank to supply the Bloom generator with a **minimum** gas pressure of **100 PSI (6.9 BAR)**.

WARNING DO NOT EXCEED 120 PSI (8.3 BAR) IN GAS PRESSURE

Excessive gas pressure may compromise seals inside the generator and result in a sudden drop in pressure. If this occurs, close the gas flow meter completely, reduce the gas pressure feeding the generator, and then slowly reopen the valve again to the desired gas flow set point.

2. Apply soapy water to gas fittings and connectors to ensure there are no gas leaks. If leaks are detected, then tighten fittings and / or connectors.
3. Gas flow rates can be adjusted depending on application and desired effect. The Bloom generators are designed to deliver a spectrum of nano and / or micro bubbles to meet the requirements of the process or application. Low gas flow rates produce more nanobubbles and have a higher gas transfer efficiency, whereas higher gas flow rates produce both nano and microbubbles that have a lower gas transfer efficiency, but higher mass transfer rate. Refer to the specification table for suggested gas flow rates for the different size units.

Gas Pressure Switch and Low Pressure Warning Light

This product is equipped with a pressure switch located outside of the automatic gas inlet valve.

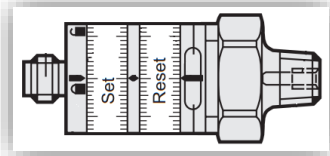

1. The default setpoint for the supply gas pressure switch is **40 PSI (2.75 BAR)**.
2. If the supply gas pressure drops below the setpoint, the red Low Gas Pressure Warning Light will turn on and the automatic gas inlet valve will close. The unit will continue to inject oxygen for as long as gas pressure exceeds pump discharge pressure.
3. The **maximum** supply pressure is **120 PSI (8.3 BAR)**.

NOTE: Operating the system with lower than the recommended supply pressure may impact the ability to provide the optimal gas flow rate and will result in less than optimal performance.

4. The gas pressure switch setpoint can be changed to expand or restrict the operating range of the Bloom generator.
5. Gas pressure and pump discharge pressure can be checked using the gauges on the front of the Bloom.

To change the supply gas pressure switch setpoint:

1. Rotate the locking ring on the top of the pressure switch clockwise, until the “UNLOCK” symbol lines up with the setting marks.
2. Rotate the SET and RESET dials to the desired setpoint.

NOTE: It is recommended to keep the SET and RESET dials at the same pressure.

3. Rotate the locking ring on the top of the pressure switch counterclockwise, until the “LOCK” symbol lines up with the setting marks.

System Operation



Pump must be fully primed before initial operation. The pump is capable of self-priming if there is sufficient water in the pump strainer basket.



Operation at or near zero flow can cause extreme heat, personal injury, or property damage.

1. Open the intake and discharge valves to flood piping and prime the pump. **Pump is primed by removing the strainer lid, filling the strainer basket with water, and replacing the strainer lid before starting. It will take a few minutes for the pump to reach full flow and the strainer basket is full, as can be seen through the lid.**

NOTE: If the Bloom generator is located above the water line of the tank or water body, it is important to install a check valve just above the intake screen.



Leaks in suction piping may only be visible while pump is off and piping is flooded. Leaks in suction piping may draw air into the system and impact performance.

2. Turn green selector switch to “ON” and run pump at normal operating conditions and check the piping for visible leaks. If necessary, adjust the pipe supports.

NOTE: Normal operating pressure range on the pump is between 13 PSIG and 25 PSIG (0.9 BAR to 1.7 BAR). Pump flow rates should be +/- 10% of the system’s designed flow. Pump flow rates lower than the system specifications will result in larger bubbles and lower oxygen transfer efficiencies – it is NOT recommended.



Do NOT exceed 25 PSI (1.72 BAR) on pump pressure.

- Every Bloom unit comes with an adjustable rotameter (see general arrangement). The valve knob on the rotameter allows for adjustment of the gas flow. Refer to the table below for the maximum and optimal flow.

Model	Maximum Gas Flow (CFH / LPM)	Optimal Gas Flow (CFH / LPM)
Bloom 25	2.5 / 1.2	1.5 / 0.6
Bloom 50	5 / 2.3	2.5 / 1.2
Bloom 150	15 / 7	7.5 / 3.5

NOTE: Operating the system with lower than the recommended supply pressure may impact the ability to provide the optimal gas flow rate and will result in less than optimal performance.

Automatic Operation

Automatic Operation can be selected by turning the green selector switch to the “AUTO” position. This switch will light up when either mode has been selected.

Controller Operation

The four button / LED display interface allows continuous monitoring of sensor values, as well as for quick changes to LOW and HIGH setpoints. The screen displays the real-time reading from the Dissolved Oxygen sensor and if the reading is currently below the LOW or above the HIGH setpoints.



The controller is factory programmed to measure the supplied Dissolved Oxygen sensor’s maximum range of 0.00 to 40.00 mg/L.

When the sensor reading is below the LOW setpoint, the “1” indicator on the display will be lit. The “2” indicator on

the display will be lit when the sensor reading is above the HIGH setpoint.



By default, the LOW and HIGH setpoints are set to 15.00 mg/L and 25.00 mg/L, respectively. The system’s response to these setpoints and how to change them are described below.

Controller Operating Manual

Manual supplied separately.

Dissolved Oxygen Sensor

Manual supplied separately.

Oxygen Injection Mode

Regardless of operating mode, the controller will display the current dissolved oxygen reading while the system is plugged in.



When the Bloom system is first plugged in, the sensor will perform a self-calibration for approximately ten seconds. Starting automatic operation before this calibration is complete may cause undesired operation.

- If “AUTO” mode is first selected when the current DO reading is below the “HIGH” setpoint, or if the DO reading drops below the LOW setpoint, the system will enter Oxygen Injection Mode.
- Sensors in the Bloom have been included to detect that the pump has started and is producing pressure, and that the oxygen supply pressure is above the minimum value. If these conditions are

met, the green “Oxygen Injection” light on the front panel of the Bloom will light up, the oxygen valve will open, and the system will begin injecting oxygen.

3. The system will continue injecting oxygen until the “HIGH” setpoint is reached. At this point, the system will stop injecting oxygen and switch over to timer mode.

Timer Mode

The Bloom utilizes an optical sensor, which does not consume dissolved oxygen. Therefore, it is necessary to periodically circulate water through the system to obtain a dissolved oxygen reading that is representative of the supply tank or reservoir.

1. The system will wait for a given interval before running the pump to perform a check of the DO level, repeating the process indefinitely. During these checks, the green “Oxygen Injection” light on the front panel will not light up, and the oxygen valve will not open.
2. The light on the selector switch will remain lit while the system is in timer mode.
3. The factory default setting for the DO check duration is **ten minutes**, and the default interval between checks is **one hour**. Instructions to change these intervals are provided below.
4. Once the DO reading drops below the LOW setpoint, timer mode will end and the system will return to oxygen injection mode.

Changing Setpoints

To change the LOW setpoint:

1. Press the → or ← buttons to begin toggling through the menu.
2. When the display shows “SP1”, press the ↵ button.
3. The current LOW setpoint will be displayed. Press and hold the → or ← buttons to begin changing the setpoint.
4. Once the desired value has been reached, press the ↵ button to confirm the value.
5. The text “STRD” will display on the screen before return to the current reading.

To change the HIGH setpoint:

1. Press the → or ← buttons to begin toggling through the menu.

2. When the display shows “SP2”, press the ↵ button.
3. The current HIGH set point will be displayed. Press and hold the → or ← buttons to begin changing the setpoint.
4. Once the desired value has been reached, press the ↵ button to confirm the value.
5. The text “STRD” will display on the screen before return to the current reading.



Ensure that SP1 is the LOW setpoint and SP2 is the HIGH setpoint. Reversing these values may cause undesired operation.

Menu Navigation

The controller will enter Normal Run Mode when first powered on, and should only be manipulated to change the HIGH and LOW setpoints.

If the controls are manipulated to navigate away from Normal Run Mode or changing SP1 or SP2, the display will cycle through the other options in “Operating Mode”.

Level 2	Level 3	Level 4	Notes
RUN			Normal Run Mode, process value displayed, SP1 in optional secondary display
SP1			Shortcut to change Setpoint 1, current Setpoint 1 value in main display
SP2			Shortcut to change Setpoint 2, current Setpoint 2 value in main display
MANL	M.CNT		Manual Mode, the RIGHT and LEFT buttons control output, displays M##.#
	M.INP		Manual Mode, the RIGHT and LEFT buttons simulate the input for testing
PAUS			Pause and hold at current process value, display flashes
StOP			Stop controlling, turn off outputs, process value rotating flash, Alarms remain
LRSt			Clears any latched Alarms; Alarms menu also allows digital input reset
VALy			Displays the lowest input reading since the VALy was last cleared
PEAK			Displays the highest input reading since the PEAK was last cleared
Stby			Standby Mode, outputs, and Alarm conditions disabled, displays Stby
TARE			TARE option - only available if enabled in INPT

To return to Normal Run Mode from anywhere in the menu structure:

1. Navigate to the top level menu by pressing the ↑ button several times. The top level menu will have the options “oPER”, “PRoG”, and “INIt”.
2. Enter Operating Mode by selecting “oPER” with the → or ← buttons and press the ↵ button.
3. Select RUN with the ↵ button to enter Normal Run Mode.



The controller will continue to operate if the menu is navigated away from normal run mode. However, the display will not return to the current reading until the operator navigates back to normal run mode.

Changing Check Duration and Interval Between Dissolved Oxygen Checks

The factory default setting for the DO check duration is **ten minutes**, and the default interval between checks is **one hour**. The timer comes preset with a maximum range of 9 hours 59 minutes for the “OFF” setting and 99.9 minutes for the “ON” setting.

To change the timer intervals:

1. **While Automation Operation is selected and the system is in Timer Mode**, open the Bloom Electrical Box to access the internal time. The Timer display will be lit when Timer Mode is active.

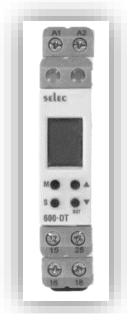

2. Hold the “S” button for five seconds.
3. The “ON” duration will display. Use the arrows to adjust the value and press the “S” button to advance to the next position.

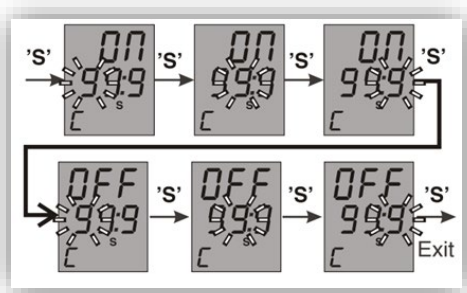

4. After the “OFF” duration is entered and the “S” button is pressed again, Time Set mode is exited and all parameters are saved.
5. After making changes, close and secure electrical box door. Turn selector switch to “OFF” and back to “AUTO” to restart Timer Mode with updated settings.

CAUTION

Ensure that the “ON” duration is long enough for the pump to sufficiently circulate the water volume in the supply tank / reservoir.

If a different maximum duration is desired, the value can be changed. Time ranges of 99:9 Sec, 999 Sec, 9:59 M:S, 99:9M, 999 M, 9:59 H:M, 99:9 H, and 999 H are available.

To change the maximum durations:

1. **While Automation Operation is selected and the system is in Timer Mode**, press and hold the “M” button on the timer for three seconds. The Timer display will be lit when Timer Mode is active.
2. Advance through the parameters by pressing the “S” button. The screen will display “ON” and “OFF” to indicate the maximum durations can be changed.
3. Adjust the maximum duration using the arrows.
4. Press and hold the “M” button on the timer for three seconds to exit configuration mode and save settings.
5. Check timer intervals to confirm the desired durations are set.
6. After making changes, close and secure electrical box door. Turn selector switch to “OFF” and back to “AUTO” to restart Timer Mode with updated settings.

CAUTION

Improperly changing the maximum interval durations set by the factory can lead to undesired operation.

WARNING

The default timer operating mode is mode “C”. Changing the operating mode may result in undesired operation.

Continuous Operation

Continuous Operation can be selected by turning the green selector switch to the “ON” position. This switch will light up when either mode has been selected.

When Continuous Operation is selected, the system will bypass the controller and enter the Oxygen Injection Mode.

1. The pump will start. The Bloom’s sensors will determine if the pump is started and is producing pressure, and if the gas supply pressure is above the minimum value.
2. If these conditions are met, the green “Oxygen Injection” light on the front panel of the Bloom will

light up, and the oxygen valve will open. The system will begin injecting oxygen.

- The controller on the Bloom will continue to display the current dissolved oxygen reading. In Continuous Operation, the setpoints will have no impact on operation.

WARNING

In continuous operation mode, the system will continue to run until the selector switch is turned to "OFF". If low customer gas supply is detected, the oxygen valve will close, but the pump will continue to run.

Intermittent Operation (Standard Bloom Only)

Continuous Operation can be selected by turning the green selector switch to the "ON" position. This switch will light up when either mode has been selected.

When Continuous Operation is selected, the system will bypass the controller and enter the Oxygen Injection Mode.

- The pump will start, and the Bloom's sensors will determine if the pump is started and is producing pressure, and if the gas supply pressure is above the minimum value.
- If these conditions are met, the green "Oxygen Injection" light on the front panel of the Bloom will light up, the oxygen valve will open. The system will begin injecting oxygen.
- The controller on the Bloom will continue to display the current dissolved oxygen reading. In Continuous Operation, the setpoints will have no impact on operation.

Pump Maintenance

CAUTION

Do NOT open the strainer pot if pump fails to prime or if pump has been operating without water in the strainer pot. Pumps operated in these circumstances may experience a buildup of vapor pressure and may contain scalding hot water. Opening the pump may cause serious personal injury. In order to avoid the possibility of personal injury, make sure the suction and discharge valves are open and strainer pot temperature is cool to touch, then open with extreme caution.

WARNING

To prevent damage to the pump and for proper operation of the system, clean pump strainer and system regularly.

Pump Strainer Basket Care

The strainer basket (or 'strainer pot'), is located in front of the pump housing. The strainer basket must be kept clean and free of debris. Inspect basket through the lid on the top of the housing.

Be sure to visually inspect the strainer basket every one to four weeks. Dirty strainer baskets reduce filter and heater efficiency and put abnormal stress on the pump motor. Bacterial fouling could cause the lid to not be clear.

Cleaning the Pump Strainer Basket

- Turn off the pump at the circuit breaker.
- Relieve pressure in the system.
- Turn the lid and clamp counterclockwise and remove from the pump.
- Remove debris and rinse out the basket. Replace the basket if it is cracked.
- Put the basket back into the housing. Be sure to align the notch in the bottom of the basket with the rib in the bottom of the volute.
- Fill the pump pot and volute up to the inlet port with water.
- Clean the lid and clamp, O-ring, and sealing surface of the pump pot.

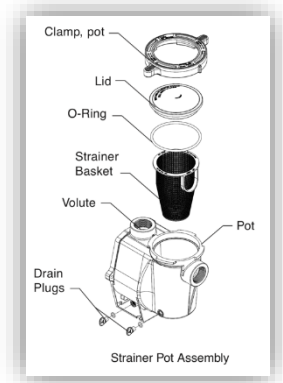

NOTE: It is important to keep the lid O-ring clean and well lubricated.

- Reinstall the lid by placing the clamp and lid on the pot. Be sure the lid O-ring is properly placed. Seat the clamp and lid on the pump then turn clockwise until the locking ring handles are horizontal.
- Turn the power "ON" at the circuit breaker.
- Open the manual air relief valve on the top of the filter. Stand clear of the filter.
- Wait until all pressure is relieved. Start the pump.
- Bleed air from the filter until a steady stream of water comes out of the filter air relief valve. Close the manual air relief valve.

⚠️ WARNING

THIS SYSTEM OPERATES UNDER HIGH PRESSURE

When any part of the circulating system (e.g., Lock Ring, Pump, Filter, Valves, etc.) is serviced, air can enter the system and become pressurized. Pressurized air can cause the lid to separate, which can result in serious injury, death, or property damage. To avoid this potential hazard, follow the above instructions.

⚠️ CAUTION

Be sure not to scratch or mar the polished shaft seal faces; seal will leak if faces are damaged. The polished and lapped faces of the seal could be damaged if not handled with care.

Winterizing

1. In mild climate areas, when temporary freezing conditions may occur, run your filtering equipment all night to prevent freezing.
2. You are responsible for determining when freezing conditions may occur. If freezing conditions are expected, take the following steps to reduce the risk of freeze damage. **Freeze damage is not covered under warranty.**

To prevent freeze damage, follow the procedures below:

1. Shut off electrical power for the pump at the circuit breaker.
2. Drain the water out of the pump housing by removing the two thumb-twist drain plugs from the housing. Store the plugs in the pump basket.
3. Cover the motor to protect it from severe rain, snow, and ice.

NOTE: Do not wrap motor with plastic or other airtight materials during winter storage. The motor may be covered during a storm, winter storage, etc., but never when operating or expecting operation.

⚠️ WARNING

PUMP SERVICE

Always disconnect power to the Bloom generator and / or pump at the circuit breaker before servicing the pump. Failure to do so could result in death or serious injury to service people, users or others due to electric shock. Read all servicing instructions before working on the pump.

⚠️ WARNING

Do NOT open the strainer pot if pump fails to prime or if pump has been operating without water in the strainer pot. Pumps operated in these circumstances may experience a build-up of vapor pressure and may contain scalding hot water. Opening the pump may cause serious personal injury. In order to avoid the possibility of personal injury, make sure the suction and discharge valves are open and strainer pot temperature is cool to touch, then open with extreme caution.

Motor Care

Protect from Heat

1. It is recommended to shade the Bloom generator from the direct sun.
2. Provide ample cross ventilation to prevent overheating.

Protect Against Dirt

1. Protect from any foreign matter or splashing water.
2. Do not store (or spill) chemicals on or near the motor.
3. Protect from any foreign matter or splashing water.
4. Avoid sweeping or stirring up dust near the motor while it is operating.
5. If a motor has been damaged by dirt it voids the motor warranty.
6. Clean the lid and clamp, O-ring, and sealing surface of the pump pot.

Protect Against Moisture

1. Protect from splashing or sprayed water.
2. Protect from extreme weather.
3. Protect from any foreign matter or splashing water.
4. If a motor has become wet, let it dry before operating. Do not allow the pump to operate if it has been flooded.
5. If a motor has been damaged by water the motor warranty is voided.

Shaft Seal Replacement

The shaft seal consists primarily of two parts, a spring-loaded member, and rotating ceramic seal. The pump requires little or no service other than reasonable care; however, a shaft seal may occasionally become damaged and must be replaced.

NOTE: The polished and lapped faces of the seal could be damaged if not handled with care.

Pump Disassembly

Tools Required

1. A 3/32" Allen head wrench
2. Two 9/16" open end wrenches
3. No. 2 or 3 Phillips head screwdriver
4. Adjustable wrench
5. 1/4" Allen head wrench

To remove and repair the motor subassembly, follow the steps below:

1. Turn off the pump circuit breaker at the main panel.
2. Drain the pump by removing the drain plugs. No tools are required.
3. Use the 9/16" wrenches to remove the six bolts that hold the housing (strainer pot / volute) to the rear subassembly.
4. Gently pull the two pump halves apart, removing the rear subassembly.
5. Use a 3/32" Allen head wrench to loosen the two holding screws located on the diffuser.
6. Hold the impeller securely in place and remove the impeller lock screw by using a Phillips head screwdriver. The screw is a left-handed thread and loosens in a clockwise direction.
7. Use a 1/4" Allen wrench to hold the motor shaft in the rear of the motor. The motor shaft has a slot on the end which is accessible through the center of the fan cover.
8. To unscrew the impeller from the shaft, twist the impeller counterclockwise.
9. If the seal needs replacing, remove the white-colored, rotating portion of the mechanical seal from the impeller.
10. Remove the four bolts from the seal plate to the motor, using a 9/16" wrench.
11. Place the seal plate face down on a flat surface and tap out the carbon spring seat.
12. Clean the seal plate, seal bore, and the motor shaft.

Pump Reassembly

1. When installing the replacement shaft seal, use silicone sealant on the metal portion before pressing into the seal plate, being careful to keep off of the seal face. Be sure the seal is fully seated and allow 24 hours for sealant to cure. (Complete seal plate with seal replacement kit available, P/N 350101SS).
2. Before installing the rotating portion of the seal into the impeller, be sure the impeller is clean. Use a light density soap and water to lubricate the inside of the seal. Press the seal into the impeller with your thumbs and wipe off the ceramic and carbon faces with a clean cloth.
3. Remount the seal plate to the motor.
4. Grease the motor shaft thread and screw impeller onto the motor shaft.
5. Screw in the impeller lock screw (counterclockwise to tighten).
6. Remount the diffuser onto the seal plate. Be sure the plastic pins and holding screw inserts are aligned.
7. Grease the diffuser O-ring and seal plate gasket prior to reassembly.
8. Assemble the motor subassembly to the pump housing by using the two through bolts for proper alignment. Do not tighten the through bolts until all six bolts are in place and finger tightened.
9. Fill the pump with water.
10. Reinstall the pump lid and plastic clamp. Refer to "Cleaning the Pump Strainer Basket" on page 10.
11. Prime the pump. Follow the Restart Instructions in the next section for startup.

Restart Instructions

If pump is installed below the water level, close return and suction lines prior to opening the strainer pot on the pump. Be sure to re-open valves prior to operating.

Priming the Pump

The pump strainer pot must be filled with water before the pump is initially started. Follow the steps below to prime the pump:

1. Remove the pump lid plastic clamp. Remove the pump lid.
2. Fill the pump strainer pot with water.
3. Reassemble the pump lid and locking ring onto the strainer pot. The pump is now ready to prime.

4. Open the air relief valve on the filter and stand clear of the filter.
5. Turn on the pump.
6. When water comes out of the filter air relief valve, close the valve. The system should now be free of air and recirculating water throughout the system.
7. For variable speed and two speed pumps, pump should run on high speed for priming.



WARNING The pump should not run longer than eight minutes if priming is not achieved.

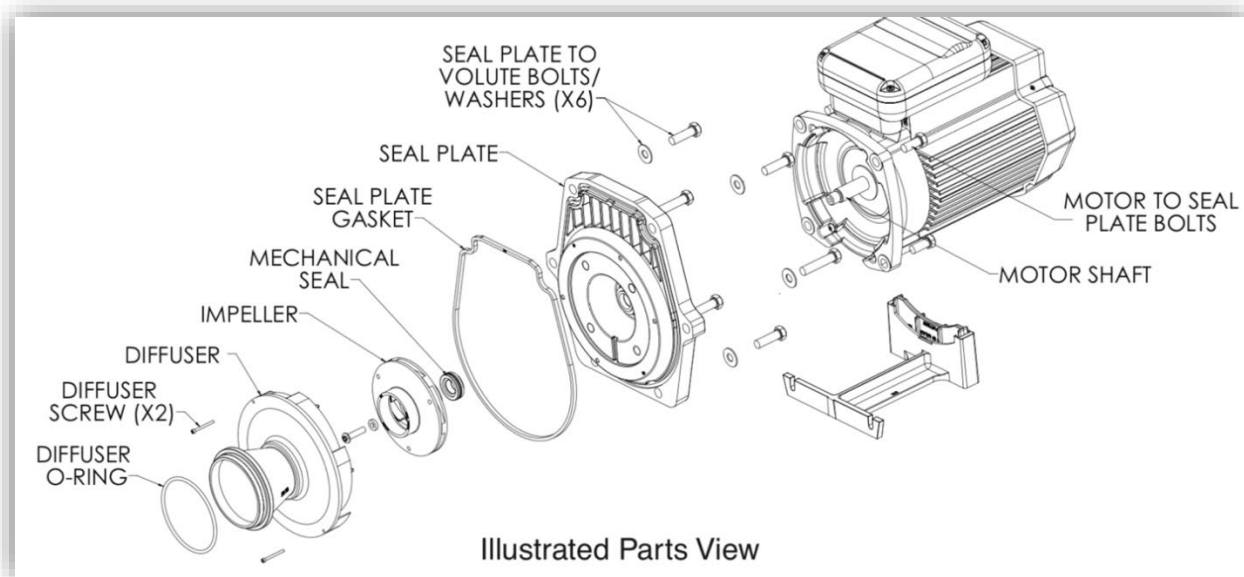

CAUTION Do NOT run the pump dry. If the pump is run dry, the mechanical seal will be damaged, and the pump will start leaking. If this occurs, the damaged seal must be replaced. ALWAYS maintain proper water level. If the water level falls below the suction port, the pump will draw air through the suction port, losing the prime and causing the pump to run dry, resulting in a damaged seal. Continued operation in this manner could cause a loss of pressure, resulting in damage to the pump case, impeller and seal and may cause property damage and personal injury.

Cleaning and Sanitizing

In normal operation, the internal elements of the Bloom generator can become fouled by mineral scale, biological matter, colloidal particles, and insoluble organic constituents. Deposits can build up on the internal surfaces during operation and can cause diminished operation. Best

practices include routine preventative cleaning with acid and alkali chemicals. In some instances, if large solids can pass into the generator, blockages can occur.

General Cleaning Procedures

1. Prepare the cleaning solution
2. Introduce the cleaning solution
3. Recycle
4. Soak
5. Conduct high-flow pumping
6. Flush out
7. Restart

Safety Precautions

1. **Maximum Temperature:** 100°C (212°F).
2. **pH Tolerance Range:** 2 to 14.
3. Each cleaning situation is different; therefore, specific cleaning recommendations are dependent on the type of foulant. Consult the general cleaning instructions for information that is common to all types of cleaning such as suggested equipment, pH and temperature limits and recommended flow rates; then apply the specific recommendation as needed.
4. When using any chemical indicated here or in subsequent sections, follow accepted safety practices. Consult the chemical manufacturer for detailed information about safety, handling, and disposal.
5. When preparing cleaning solutions, ensure that all chemicals are dissolved and well mixed before circulating the solutions through the elements.

Troubleshooting Guide

Problem	Possible Cause	Corrective Action
Pump Will Not Prime	<ul style="list-style-type: none"> • Air circulating in system. • Gas valve open when pump not running. • No water in the pump strainer pot. 	<ul style="list-style-type: none"> • Check suction piping and valve on any suction gate valves. • Secure lid on pump strainer pot and be sure lid gasket is in place. Check water level to make sure suction port is not drawing air. • Be sure suction lines, pump strainer, and pump volute are full of water. Be sure valve on suction line is working and open (some systems do not have valves).
Pump Motor Not Running	<ul style="list-style-type: none"> • Motor thermal protector tripped. • Open circuit breaker or blown fuse. • Impeller binding. • Motor improperly wired. • Defective motor. 	<ul style="list-style-type: none"> • Reset overload. • Reset Breaker or replace fuse. • Clear the impeller. • Check the motor is wired correctly.
Pump Gasket Defective	<ul style="list-style-type: none"> • Defective gasket. 	<ul style="list-style-type: none"> • Replace gasket.
Reduced Capacity and / or Head	<ul style="list-style-type: none"> • Air pockets or leaks in suction line. • Pump will not prime – too much air. 	<ul style="list-style-type: none"> • Check suction piping and valve on any valve suction gate valves. • Secure lid on pump strainer pot and make sure lid gasket is in place. Check water level to make sure suction port is not drawing air. • Clean pump strainer pot. • Check to see if impeller or diffuser are clogged.
Clogged Impeller	<ul style="list-style-type: none"> • Debris in impeller. 	<ul style="list-style-type: none"> • Switch OFF electrical power at the circuit breakers to the pump. Remove the nuts that secure the volute to the seal plate. • Slide the motor and seal plate away from the volute. Clean debris from impeller. • If debris cannot be removed, complete the following steps: <ul style="list-style-type: none"> ○ Remove impeller, reverse screw, and O-ring; ○ Remove, clean, and reinstall impeller; ○ Reinstall anti-spin bolt; ○ Reinstall diffuser and O-ring;

Problem	Possible Cause	Corrective Action
		<ul style="list-style-type: none"> ○ Reinstall motor and seal plate into volute; ○ Reinstall hardware around seal plate and volute and tighten securely.
Pump Strainer Clogged	<ul style="list-style-type: none"> • Debris in pump strainer basket. 	<ul style="list-style-type: none"> • Clean suction trap.
Insufficient Dissolved Oxygen Saturation	<ul style="list-style-type: none"> • Vacuum leaks in suction line. • Gas flow too low. 	<ul style="list-style-type: none"> • Check plumbing connections and suction piping. • Check to be sure suction port is not drawing air into the system. • Increase gas flow. • Increase system run time.
Excessive Power Consumption	<ul style="list-style-type: none"> • Impeller binding. • NPSH too low – excessive suction lift or losses. • Discharge head too low – excessive flow rate. 	<ul style="list-style-type: none"> • Check impeller. • Check the pump curve for NPSH requirements. • Check the flow.
Pump Flow Too Low	<ul style="list-style-type: none"> • Voltage too low. 	<ul style="list-style-type: none"> • Check and correct the voltage.
Pump Back Pressure Too High	<ul style="list-style-type: none"> • Discharge nozzle or piping obstructed. • Discharge valve engaged too much. 	<ul style="list-style-type: none"> • Check for blockage in piping. • Ensure all valves are fully open.
Low Gas Pressure on System Gauge	<ul style="list-style-type: none"> • Feed gas pressure too low. • Internal fouling. 	<ul style="list-style-type: none"> • Follows specified “clean-in-place” procedures to internal cleaning. • Increase flow rate.
Gas Flow Meter Not Working	<ul style="list-style-type: none"> • Moisture in the Rotameter. • Blockage in needle valve. 	<ul style="list-style-type: none"> • Clean Rotameter.
Too Many large Bubbles	<ul style="list-style-type: none"> • Gas flow too high. 	<ul style="list-style-type: none"> • Reduce gas flow.
Insufficient Gas Transfer	<ul style="list-style-type: none"> • Feed gas pressure too low. • Delta gas pressure out of range. • Excessive moisture and / or contaminant in the gas line. • Internal system fouling. 	<ul style="list-style-type: none"> • Increase feed gas pressure at the gas regulator. • Clean Rotameter, gas lines, and fittings. • Follow specified “clean-in-place” procedures for internal cleaning.

Problem	Possible Cause	Corrective Action
Excessive Noise and Vibration	<ul style="list-style-type: none"> • Impeller binding. • Pump is not primed fully – air or gases in pumpage. • NPSH too low – excessive suction lift or losses. • Incorrect rotation (3 phase only). • Defective motor. • Discharge, suction plugged, or valve closed. • Impeller worn or plugged. 	<ul style="list-style-type: none"> • Replace impeller if damaged. • Completely flood intake piping to prime fully. • Repair or replace motor if damaged. • Open discharge valve or reduce restriction.
Automatic Mode Selected but System Not Running	<ul style="list-style-type: none"> • System currently in Timer Mode. • Timer settings entered incorrectly. 	<ul style="list-style-type: none"> • Confirm Selector Switch is lit and system receiving power. • Check / change setpoints on controller. • Check / change interval durations on timer.
System Frequently Stops / Restarts in Automatic Mode	<ul style="list-style-type: none"> • HIGH / LOW setpoints inverted. 	<ul style="list-style-type: none"> • Ensure LOW setpoint is mapped to SP1 and HIGH setpoint is mapped to SP2 on controller.
Controller Displays “OPEN” Signal from Dissolved Oxygen Sensor Lost	<ul style="list-style-type: none"> • Dissolved oxygen sensor is damaged. 	<ul style="list-style-type: none"> • Verify no visible damage to sensor and that LED on sensor body is lit when first powered up.. • Replace sensor if damaged.

Pump Performance Curves

The 25 Bloom uses SP-2 pump, the 50 Bloom uses the SP-3 pump, and the 150 Bloom uses the SP-12 pump.

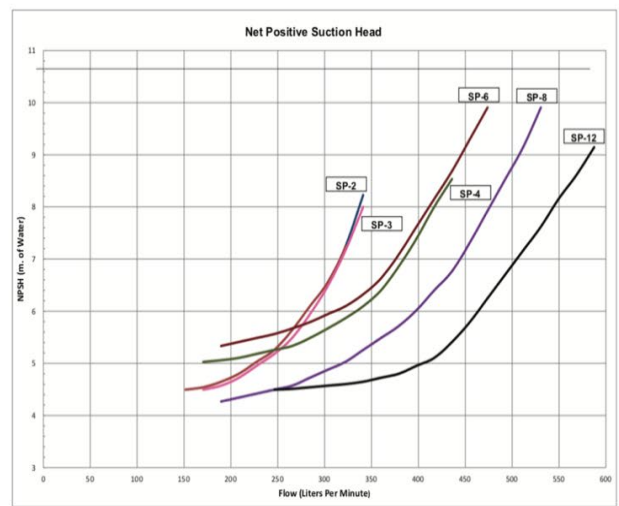
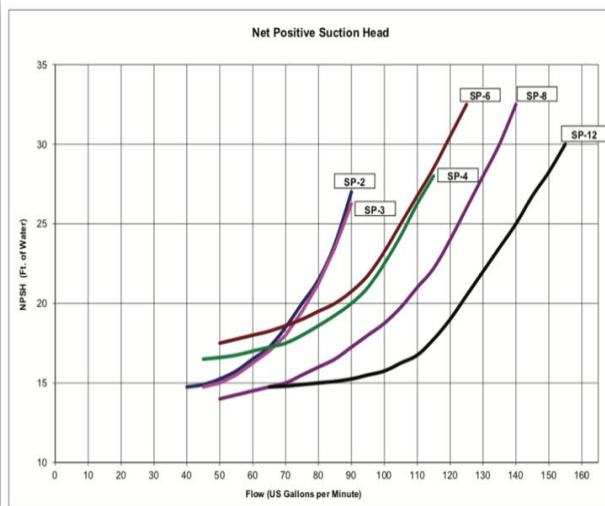
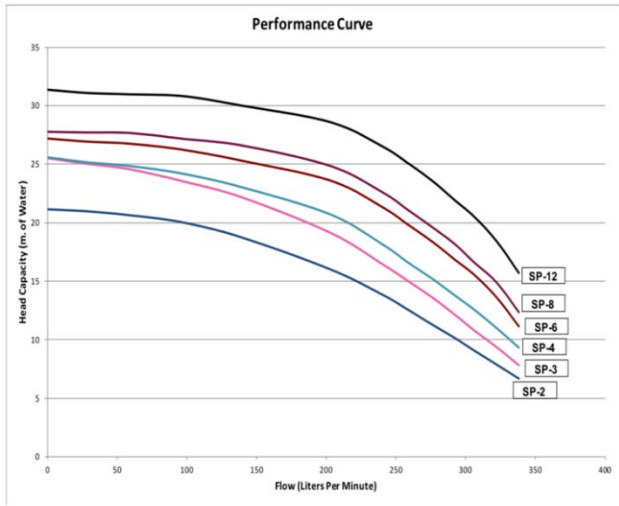
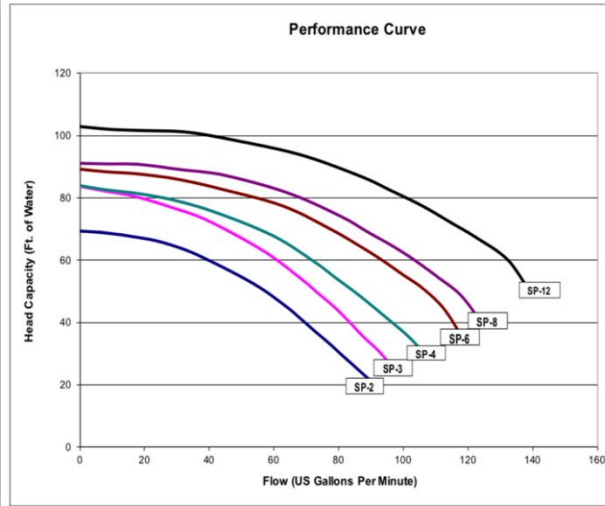

Limited Warranty

Warranty

Moleaer warrants that the Goods will be free from defects in material and workmanship for a period of 12 months from delivery. Moleaer shall in no event be liable for defects or damage attributable to modifications performed or repair work done other than by Moleaer personnel or to abuse, accident, catastrophe, force majeure event, shipment, improper use including but not limited to circumstances where pumps and / or compressors included in the Goods are not operated in accordance with the original pump or compressor manufacturer's specifications, maintenance, storage or application or any other external cause.

EXCEPT FOR ANY WRITTEN PERFORMANCE WARRANTY THAT MOLEAER HAS EXPRESSLY INCORPORATED IN THIS CONTRACT, MOLEAER DISCLAIMS ALL OTHER WARRANTIES, WHETHER EXPRESS OR IMPLIED, INCLUDING ANY WARRANTY OF MERCHANTABILITY, FITNESS FOR A PARTICULAR PURPOSE AND NON-INFRINGEMENT.

Claims; Exclusive Remedy

Any warranty claim must be made to Moleaer in writing within ten days of discovery of the alleged defect. After obtaining prior written authorization from Moleaer, Buyer shall return all allegedly defective Goods, freight pre-paid, for examination by Moleaer. If Moleaer finds that the Goods are defective and covered by the warranty, Moleaer's sole obligation shall be, at Moleaer's option, to repair or replace the Goods, or to refund the purchase price therefor, and to reimburse Buyer's reasonable shipping costs. Buyer shall be responsible for all charges for handling of returned items not found defective. The remedy set forth in this Paragraph 4 is Buyer's sole and exclusive remedy for any breach of warranty or claim related to the Goods other than pursuant to any written performance warranty that Moleaer has expressly incorporated in this Contract.

Limited Warranty

MOLEAER SHALL NOT BE MOLEAER SHALL NOT BE LIABLE FOR SPECIAL, INDIRECT, CONSEQUENTIAL OR INCIDENTAL DAMAGES, INCLUDING DAMAGES FOR LOST OR PROSPECTIVE PROFITS OR OTHER ECONOMIC DAMAGES, ARISING OUT OF OR RELATED TO THIS CONTRACT OR THE GOODS. MOLEAER'S TOTAL LIABILITY, WHETHER IN CONTRACT OR TORT OR OTHERWISE, SHALL NOT EXCEED THE PORTION OF THE PRICE PAID BY BUYER ALLOCABLE TO THE GOODS GIVING RISE TO THE LIABILITY. THE LIMITATIONS IN THIS PARAGRAPH WILL APPLY

NOTWITHSTANDING THE FAILURE OF ESSENTIAL PURPOSE OF ANY LIMITED REMEDY.

This limitation shall not apply to claims for personal injury directly caused by Moleaer's willful or reckless acts.

PLEASE CONTACT MOLEAER AT 424-558-3567 IF YOU HAVE ANY QUESTIONS, OR TO ASSIST WITH ANY TROUBLESHOOTING AND FIELD INSTALLATION QUESTIONS.



BEYOND AERATION

20800 BELSHAW AVENUE
CARSON, CA 90746 USA

+1-424-558-3567

info@moleaer.com

www.moleaer.com

